

SKF Power Transmission products





Couplings



Grid couplings 106



Gear couplings 111



Disc couplings 121



SKF Flex couplings 131



SKF Flex spacer coupling 133



Chain couplings 135



Rigid couplings 137



FRC couplings 139



Jaw couplings 141



Universal joints 143

SKF Couplings

SKF coupling range nomenclature has a defined prefix of PHE. The coupling range is covered by limited standards, AGMA is the main standard to cover interchangeability for couplings, and spacers are covered by ANSI or ISO for lengths.

Couplings

The coupling range designation from SKF has the following is an example to indicate set up.

SKF Designation prefix

PHE F90 HTB FLG

Coupling size and type

Example:

F90 - Flex coupling size 90

1070TG – taper grid coupling size 1070

Supplementary

Many different supplementary designations, examples

HTB- taper bushing type H

NR – insert type Nitrile

HCOVER – cover type H, horizontal

Note

See SKF product training for full supplementary notations

Supplementary

Many different supplementary designations, example

FLG – flange hub only for Flex coupling

Couplings (PHE Product Group)

SKF Flex-, Chain-, FRC-, Jaw couplings and Universal joints are manufactured according to established market standards and are fully interchangeable with other brands:

- Metric bore keyway machined according to BS 4231:Part 1 and DIN 6885;
- British imperial bore keyway machined according to BS 46:Part 1; and
- American imperial bore keyway machined according to ASME B17.1.

SKF Grid, Gear and Rigid couplings are manufactured according to established industrial standard, which is acceptable throughout the world.

SKF Gear couplings are interchangeable, half to half, to industries standard using AGMA bolt pattern.

Every coupling is protected by a specific treatment, which depends on the material or type of packaging: (1) phosphate coating, (2) blackening, (3) spray painting or (4) anti-corrosion oil.

Main materials used in couplings

SKF Flex coupling	Flange in grey cast iron HT250; tyre available in nitrile or chloroprene (FRAS); rubber and spacer in grey cast Iron HT250.
Chain coupling	Flange in premium carbon steel no. 45 and cover available in aluminium and plastic.
FRC coupling	Flange in grey cast iron HT250 and elements available in nitrile or chloroprene (FRAS) rubber.
Jaw coupling	Flange in grey cast iron HT250; spacer in aluminium and insert available in nitrile, urethane and Hytrel®.
Gear coupling	Hub in steel SM45C equivalent to AISI 1045; grid member in spring steel SW-C; horizontal split cover in aluminium.
Gear coupling	Sleeve and hub in steel SM45C equivalent to AISI 1045.
Rigid coupling	All components manufactured in grey cast iron HT250.
Universal Joint	Premium carbon steel.

Grid couplings

In high output (kW) and high torque applications where vibration, shock loads and misalignment occur, SKF grid couplings are an excellent choice.

The unique design of the grid and hub teeth enable these couplings to accommodate movement and stresses from all three planes, thereby reducing vibration levels by as much as 30%.

The tapered grid element is manufactured from a high strength alloy steel. The grid, which is the primary wear component of the coupling, is designed for quick and easy replacement. Unlike other couplings, the hubs and other components are not disturbed. This makes realignment unnecessary and further reduces downtime and maintenance costs.

Order data

Coupling type	Hubs		Cover		Grid		Spacer hub set				
	Solid bore	Qty	Bored to size	Qty	Qty	Qty	(... = DBSE dimension)	Qty			
Horizontal split cover	PHE 1050TGRSB	2	or	PHE 1050TG...MM	2	PHE 1050TGHCOVER	1	PHE 1050TGGRID	1	–	–
Vertical split cover	PHE 1050TGRSB	2	or	PHE 1050TG...MM	2	PHE 1050TGVCOVER	1	PHE 1050TGGRID	1	–	–
Full spacer	PHE 1050TGS-SHRB	2	or	PHE 1050TGS-SH...MM	2	PHE 1050TGHCOVER	1	PHE 1050TGGRID	1	PHE 1050TGFS-SPACERX...MM	1
Half spacer	PHE 1050TGRSB	1	–	–	–	PHE 1050TGHCOVER	1	PHE 1050TGGRID	1	PHE 1050TGHS-SPACERX...MM	1
	PHE 1050TGS-SHRB	1	or	PHE 1050TGS-SH...MM	1	–	–	–	–	–	–

Each complete full or half spacer coupling consists of: 2 hubs, 1 grid, 1 cover and 1 spacer hub set. Each complete horizontal or vertical split cover coupling consists of: 2 hubs, 1 grid and 1 cover. For bored to size designations, add bore size. For example, PHE 1050TG25MM

Grid couplings

Horizontal split cover

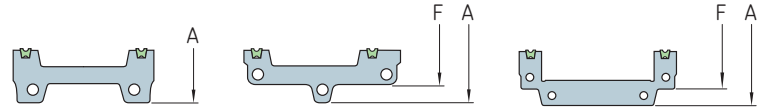
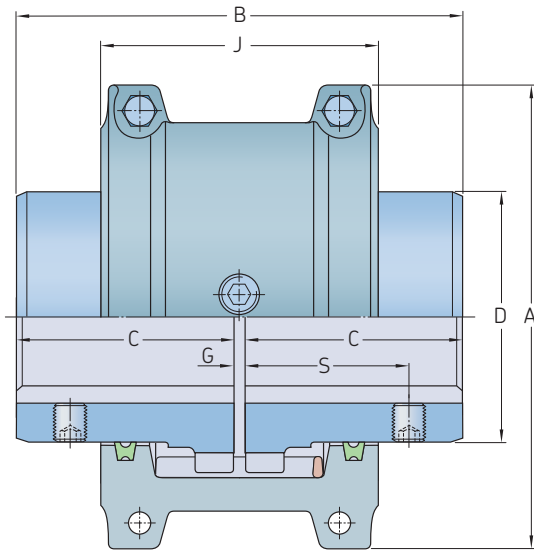

Cover profiles
Sizes 1020 - 1140

Sizes 1150 - 1200

Sizes 1210-1220

Size	Power per 100 r/min	Rated torque	Speed	Bore diameter		Dimensions						Gap			Lubricant mass	Coupling mass without bore	
				Min.	Max.	A	B	C	D	J	F	S	G Min.	Normal			Max.
–	kW	Nm	r/min	mm	mm	mm	mm	mm	mm	mm	mm	mm	mm	mm	mm	kg	kg
1020 TGH	0,54	52	4 500	12	30	101,6	98,2	47,5	39,7	66,0	–	39,1	1,5	3	4,5	0,027	1,9
1030 TGH	1,60	149	4 500	12	36	110,0	98,2	47,5	49,2	68,3	–	39,1	1,5	3	4,5	0,040	2,6
1040 TGH	2,60	249	4 500	12	44	117,5	104,6	50,8	57,2	70,0	–	40,1	1,5	3	4,5	0,054	3,4
1050 TGH	4,60	435	4 500	12	50	138,0	123,6	60,3	66,7	79,5	–	44,7	1,5	3	4,5	0,068	5,4
1060 TGH	7,20	684	4 500	19	57	150,5	130,0	63,5	76,2	92,0	–	52,3	1,5	3	4,5	0,086	7,3
1070 TGH	10,40	994	4 125	19	65	161,9	155,4	76,2	87,3	95,0	–	53,8	1,5	3	4,5	0,113	10,0
1080 TGH	21,50	2 050	3 600	27	79	194,0	180,8	88,9	104,8	116,0	–	64,5	1,5	3	6,0	0,172	18,0
1090 TGH	39,00	3 730	3 600	27	95	213,0	199,8	98,4	123,8	122,0	–	71,6	1,5	3	6,0	0,254	25,0
1100 TGH	65,70	6 280	2 440	41	107	250,0	246,2	120,6	142,1	155,5	–	–	1,5	5	9,5	0,426	42,0
1110 TGH	97,60	9 320	2 250	41	117	270,0	259,0	127,0	160,3	161,5	–	–	1,5	5	9,5	0,508	54,0
1120 TGH	143,00	13 700	2 025	60	136	308,0	304,4	149,2	179,4	191,5	–	–	1,5	6	12,5	0,735	81,0
1130 TGH	208,00	19 900	1 800	66	165	346,0	329,8	161,9	217,5	195,0	–	–	1,5	6	12,5	0,907	121,0
1140 TGH	299,00	28 600	1 650	66	184	384,0	374,4	184,2	254,0	201,0	–	–	1,5	6	12,5	1,130	178,0
1150 TGH	416,00	39 800	1 500	108	203	453,1	371,8	182,9	269,2	271,3	391,2	–	1,5	6	12,5	1,950	234,0
1160 TGH	586,00	55 900	1 350	120	228	501,4	402,2	198,1	304,8	278,9	436,9	–	1,5	6	12,5	2,810	317,0
1170 TGH	781,00	74 600	1 225	133	279	566,4	437,8	215,9	355,6	304,3	487,2	–	1,5	6	12,5	3,490	448,0
1180 TGH	1 080,00	103 000	1 100	152	311	629,9	483,6	238,8	393,7	321,1	554,7	–	1,5	6	12,5	3,760	619,0
1190 TGH	1 430,00	137 000	1 050	152	339	675,6	524,2	259,1	436,9	325,1	607,8	–	1,5	6	12,5	4,400	776,0
1200 TGH	1 950,00	186 000	900	177	361	756,9	564,8	279,4	497,8	355,6	660,4	–	1,5	6	12,5	5,620	1 057,0
1210 TGH	2 611,00	249 000	820	177	390	844,5	622,3	304,8	533,4	431,8	750,8	–	1,5	6	12,7	10,500	1 425,0
1220 TGH	3 523,00	336 000	730	203	420	920,7	662,9	325,1	571,5	490,2	822,2	–	1,5	6	12,7	16,100	1 785,0

Grid couplings
Vertical split cover

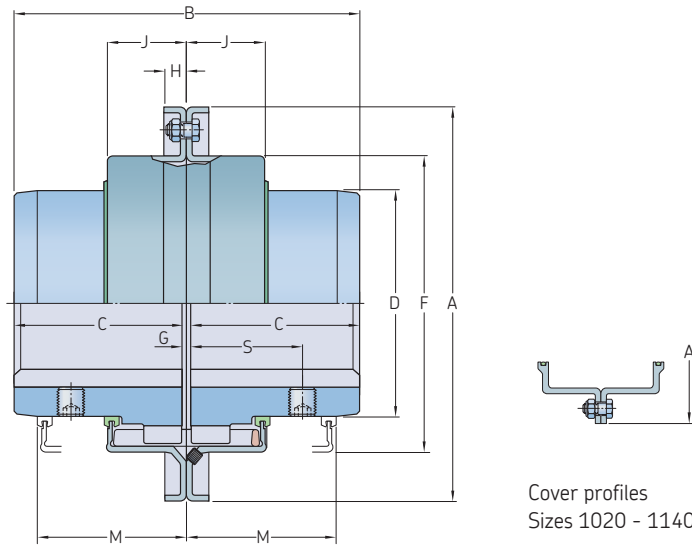

Cover profiles
Sizes 1020 - 1140

Size	Power per 100 r/min	Rated torque	Speed	Bore diameter		Dimensions										Gap			Lubricant weight	Coupling weight without bore
				Max.	Min.	A	B	C	D	F	H	J	M	S	G Min.	Normal	Max.			
–	kW	Nm	r/min	mm		mm										mm			kg	
1020 TGV	0,54	52	6 000	12	30	111,1	98,0	47,5	39,7	64,3	9,7	24,2	47,8	39,1	1,5	3	4,5	0,027	2,0	
1030 TGV	1,60	149	6 000	12	36	120,7	98,0	47,5	49,2	73,8	9,7	25,0	47,8	39,1	1,5	3	4,5	0,040	2,6	
1040 TGV	2,60	249	6 000	12	44	128,5	104,6	50,8	57,2	81,8	9,7	25,7	50,8	40,1	1,5	3	4,5	0,054	3,4	
1050 TGV	4,60	435	6 000	12	50	147,6	123,6	60,3	66,7	97,6	11,9	31,2	60,5	44,7	1,5	3	4,5	0,068	5,4	
1060 TGV	7,20	684	6 000	19	57	162,0	130,0	63,5	76,2	111,1	12,7	32,2	63,5	52,3	1,5	3	4,5	0,086	7,3	
1070 TGV	10,40	994	5 500	19	65	173,0	155,4	76,2	87,3	122,3	12,7	33,7	66,5	53,8	1,5	3	4,5	0,113	10,0	
1080 TGV	21,50	2 050	4 750	27	79	200,0	180,8	88,9	104,8	149,2	12,7	44,2	88,9	64,5	1,5	3	6,0	0,172	18,0	
1090 TGV	39,00	3 730	4 000	27	95	231,8	199,8	98,4	123,8	168,3	12,7	47,7	95,2	71,6	1,5	3	6,0	0,254	25,0	
1100 TGV	65,70	6 280	3 250	41	107	266,7	245,7	120,6	142,1	198,0	15,7	60,0	120,7	–	1,5	5	9,5	0,426	42,0	
1110 TGV	97,60	9 320	3 000	41	117	285,8	258,5	127,0	160,3	216,3	16,0	64,2	124,0	–	1,5	5	9,5	0,508	54,0	
1120 TGV	143,00	13 700	2 700	60	136	319,0	304,4	149,2	179,4	245,5	17,5	73,4	142,7	–	1,5	6	12,5	0,735	81,0	
1130 TGV	208,00	19 900	2 400	66	165	377,8	329,8	161,9	217,5	283,8	20,6	75,1	146,0	–	1,5	6	12,5	0,907	122,0	
1140 TGV	299,00	28 600	2 200	66	184	416,0	371,6	184,2	254,0	321,9	20,6	78,2	155,4	–	1,5	6	12,5	1,130	180,0	
1150 TGV	416,00	39 800	2 000	108	203	476,3	371,8	182,9	269,2	374,4	19,3	106,9	203,2	–	1,5	6	12,5	1,950	230,0	
1160 TGV	586,00	55 900	1 750	120	228	533,4	402,2	198,1	304,8	423,9	30,0	114,3	215,9	–	1,5	6	12,5	2,810	321,0	
1170 TGV	781,00	74 600	1 600	133	279	584,2	437,8	215,9	355,6	474,7	30,0	119,4	226,1	–	1,5	6	12,5	3,490	448,0	
1180 TGV	1 080,00	103 000	1 400	152	311	630,0	483,6	238,8	393,7	–	–	130,0	265,0	–	1,5	6	12,5	3,760	591,0	
1190 TGV	1 430,00	137 000	1 300	152	339	685,0	524,2	259,1	436,9	–	–	135,0	275,0	–	1,5	6	12,5	4,400	761,0	
1200 TGV	1 950,00	186 000	1 100	177	361	737,0	564,8	279,4	497,8	–	–	145,0	295,0	–	1,5	6	12,5	5,620	1 021,0	

Grid couplings

Full spacer

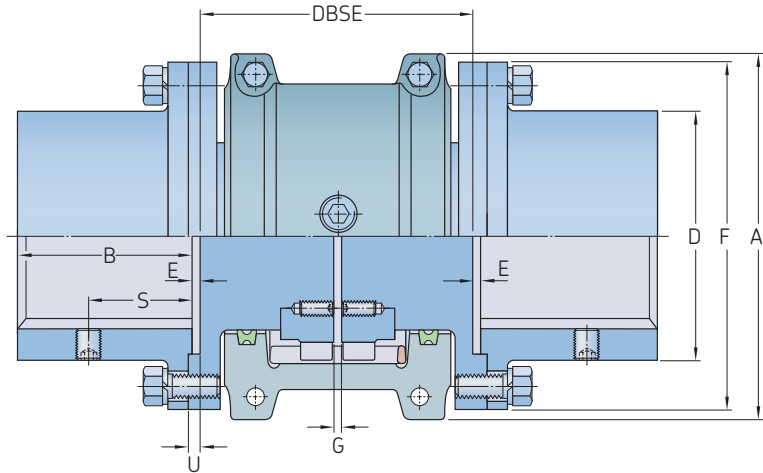

Size	Power per 100 r/min kW	Rated torque Nm	Speed r/min	Bore diameter mm		Dimensions mm										Gap mm		Flange bolts Normal Qty	Lubricant weight kg	Coupling weight without bore and min. BE
				Max.	Min.	A	B	DBSE Min.	Max.	D	E	F	S	U	G Min.					
1020 TGFS	0,54	52	3 600	12	35	101,6	35	89	203	52	0,8	86	27,4	1,8	1,5	5,0	4	0,027	3,9	
1030 TGFS	1,60	149	3 600	12	43	110,0	41	89	216	59	0,8	94	31,5	1,8	1,5	5,0	8	0,040	5,2	
1040 TGFS	2,60	249	3 600	12	56	117,5	54	89	216	78	0,8	113	27,4	1,8	1,5	5,0	8	0,054	8,4	
1050 TGFS	4,60	435	3 600	12	67	138,0	60	112	216	87	0,8	126	40,6	1,8	1,5	5,0	8	0,068	12,8	
1060 TGFS	7,20	684	3 600	19	80	150,5	73	127	330	103	1,8	145	43,2	2,8	1,5	5,0	8	0,086	20,5	
1070 TGFS	10,40	994	3 600	19	85	161,9	79	127	330	109	1,8	153	46,7	2,8	1,5	5,0	12	0,113	24,8	
1080 TGFS	21,50	2 050	3 600	27	95	194,0	89	184	406	122	1,8	178	49,8	2,8	1,5	5,0	12	0,172	40,0	
1090 TGFS	39,00	3 730	3 600	27	110	213,0	102	184	406	142	1,8	210	56,9	2,8	1,5	5,0	12	0,254	60,0	
1100 TGFS	65,70	6 280	2 440	41	130	250,0	90	203	406	171	1,6	251	-	3,2	1,5	6,5	12	0,426	90,2	
1110 TGFS	97,60	9 320	2 250	41	150	270,0	104	210	406	196	1,6	277	-	3,2	1,5	6,5	12	0,508	119,0	
1120 TGFS	143,00	13 700	2 025	60	170	308,0	119	246	406	225	1,6	319	-	4,0	1,5	9,5	12	0,735	178,0	
1130 TGFS	208,00	19 900	1 800	66	190	346,0	135	257	406	238	1,6	346	-	4,0	1,5	9,5	12	0,907	237,0	
1140 TGFS	299,00	28 600	1 650	66	210	384,0	152	267	406	266	1,6	386	-	4,0	1,5	9,5	12	1,130	327,0	
1150 TGFS	416,00	39 800	1 500	108	270	453,1	173	345	371	334	5,1	425	-	-	1,5	9,5	14	1,950	462,0	
1160 TGFS	586,00	55 900	1 350	120	290	501,4	186	356	406	366	6,6	457	-	-	1,5	9,5	14	2,810	566,0	
1170 TGFS	781,00	74 600	1 225	133	340	566,4	220	384	445	425	8,4	527	-	-	1,5	9,5	16	3,490	856,0	
1180 TGFS	1 080,00	103 000	1 100	133	340	629,9	249	400	490	451	5,1	591	-	8,1	1,5	9,5	16	3,760	1 135,0	
1190 TGFS	1 430,00	137 000	1 050	152	380	675,6	276	411	530	508	5,1	660	-	8,1	1,5	9,5	18	4,400	1 525,0	
1200 TGFS	1 950,00	186 000	900	177	400	756,9	305	445	575	530	6,1	711	-	9,1	1,5	9,5	18	5,620	1 910,0	

Grid couplings

Half spacer

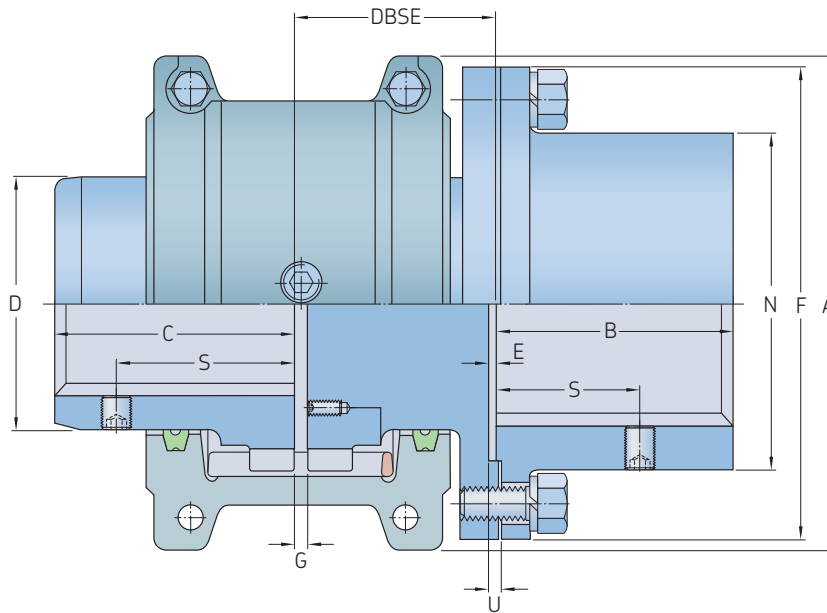

Size	Power per 100 r/min	Rated torque	Speed	Bore diameter				Dimensions										Gap			Flange bolts	Lubricant weight	Coupling weight without bore
				Max.	Min.	Max.	Max.	A	B	C	D	DBSE Min.	DBSE Max.	N	E	F	Shaft hub S	T hub S	T hub U	G Min.			
-	kW	Nm	r/min	mm				mm										mm			kg		
1020 TGHS	0,54	52	3 600	12	30	35	101,6	35	47,5	39,7	45	102	52	0,8	86	27,4	39,1	1,8	1,5	3	4	0,027	2,9
1030 TGHS	1,60	149	3 600	12	36	43	110,0	41	47,5	49,2	45	109	59	0,8	94	31,5	39,1	1,8	1,5	3	8	0,040	3,9
1040 TGHS	2,60	249	3 600	12	44	56	117,5	54	50,8	57,2	45	109	78	0,8	113	27,4	40,1	1,8	1,5	3	8	0,054	5,9
1050 TGHS	4,60	435	3 600	12	50	67	138,0	60	60,3	66,7	57	109	87	0,8	126	40,6	44,7	1,8	1,5	3	8	0,068	9,1
1060 TGHS	7,20	684	3 600	19	57	80	150,5	73	63,5	76,2	64	166	103	1,8	145	43,2	52,3	2,8	1,5	3	8	0,086	14,0
1070 TGHS	10,40	994	3 600	19	65	85	161,9	79	76,2	87,3	64	166	109	1,8	153	46,7	53,8	2,8	1,5	3	12	0,113	17,6
1080 TGHS	21,50	2 050	3 600	27	79	95	194,0	89	88,9	104,8	93	204	122	1,8	178	49,8	64,5	2,8	1,5	3	12	0,172	29,0
1090 TGHS	39,00	3 730	3 600	27	95	110	213,0	102	98,4	123,8	93	204	142	1,8	210	56,9	71,6	2,8	1,5	3	12	0,254	42,8
1100 TGHS	65,70	6 280	2 440	41	107	130	250,0	90	120,6	142,1	103	205	171	1,6	251	-	3,2	1,5	5	12	0,426	66,0	
1110 TGHS	97,60	9 320	2 250	41	117	150	270,0	104	127,0	160,3	106	205	196	1,6	277	-	-	3,2	1,5	5	12	0,508	84,5
1120 TGHS	143,00	13 700	2 025	60	136	170	308,0	119	149,2	179,4	125	205	225	1,6	319	-	-	4,0	1,5	6	12	0,735	129,0
1130 TGHS	208,00	19 900	1 800	66	165	190	346,0	135	161,9	217,5	130	205	238	1,6	346	-	-	4,0	1,5	6	12	0,907	179,0
1140 TGHS	299,00	28 600	1 650	66	184	210	384,0	152	184,2	254,0	135	205	266	1,6	386	-	-	4,0	1,5	6	12	1,130	252,0
1150 TGHS	416,00	39 800	1 500	108	203	270	453,1	173	182,9	269,2	175	187	334	5,1	425	-	-	-	1,5	6	14	1,950	348,0
1160 TGHS	586,00	55 900	1 350	120	228	290	501,4	186	198,1	304,8	180	205	366	6,6	457	-	-	-	1,5	6	14	2,810	441,0
1170 TGHS	781,00	74 600	1 225	133	279	340	566,4	220	215,9	355,6	194	224	425	8,4	527	-	-	-	1,5	6	16	3,490	652,0
1180 TGHS	1 080,00	103 000	1 100	133	311	340	629,9	249	238,8	393,7	202	247	451	5,1	591	-	-	8,1	1,5	6	16	3,760	877,0
1190 TGHS	1 430,00	137 000	1 050	152	339	380	675,6	276	259,1	436,9	207	267	508	5,1	660	-	-	8,1	1,5	6	18	4,400	1150,0
1200 TGHS	1 950,00	186 000	900	177	361	400	756,9	305	279,4	497,8	224	289	530	6,1	711	-	-	9,1	1,5	6	18	5,620	1484,0

Gear couplings

Very high-torque ratings, along with unparalleled bore capacities, give this coupling a great advantage over other types of couplings. SKF gear couplings are rated up to 555 000 Nm with a maximum bore of 495 mm. This is a heavy duty coupling with incredible design flexibility, making it an economical choice for many applications.

The unique design of the gear couplings tooth crowning dramatically reduces backlash and radial clearance. The hub bore capacities are the largest in the industry allowing for low cost and long service life.

Order data

Coupling type	Hubs	Qty	Cover	Qty	Assembly kit	Qty	Spacer/floating shaft and kits ... = DBSE dimension	Qty
Double engagement	PHE 50GCRSB	2	PHE 50GCCOVER	2	PHE 50GCKIT	1	–	–
Size 80 and above	PHE 80GCRSB	2	PHE 80GCMCOVER	1	PHE 80GCKIT	1	–	–
	–	–	PHE 80GCFCOVER	1	–	–	–	–
Single engagement	PHE 50GCSERSB	1	PHE 50GCCOVER	1	PHE 50GCKIT	1	–	–
	PHE 50GCRSB	1	–	–	–	–	–	–
Size 80 and above	PHE 80GCSERSB	1	PHE 80GCMCOVER	1	PHE 80GCKIT	1	–	–
	PHE 80GCRSB	1	–	–	–	–	–	–
Double engagement spacer	PHE 50GCRSB	2	PHE 50GCCOVER	2	PHE 50GCKIT	2	PHE 50GCSPECER...MM	1
Double engagement slide type 1, 2, 3								
Type 1	PHE 50GCRSB	2	PHE 50GSCCOVER	2	PHE 50GCKIT	1	PHE 50GCCPLATE	1
Type 2	PHE 50GCT2RSB	2	PHE 50GSCCOVER	2	PHE 50GCKIT	1	PHE 50GCCPLATE	1
Type 3	PHE 50GCRSB	2	PHE 50GCCCOVER	2	PHE 50GCKIT	1	PHE 50GCCPLATE	1
	–	–	–	–	–	–	PHE 50GCT3DISC	2
Single engagement slide type 1 and 2								
Type 1	PHE 50GCRSB	1	PHE 50GSCCOVER	1	PHE 50GCKIT	1	PHE 50GCCPLATE	1
	PHE 50GCSERSB	1	–	–	–	–	–	–
Type 2	PHE 50GCT2RSB	1	PHE 50GSCCOVER	1	PHE 50GCKIT	1	PHE 50GCCPLATE	1
	PHE 50GCSERSB	1	–	–	–	–	–	–
Single engagement floating shaft	PHE 50GCFERSB	2	PHE 50GCCOVER	2	PHE 50GCKIT	2	PHE 50GCFSHAFT .. MM	1
	PHE 50GCRSB	2	–	–	–	–	PHE 50GCFSEDISC	2
Double engagement vertical	PHE 50GCVRSB	2	PHE 50GCVCOVER	2	PHE 50GCKIT	1	50GCVCTRKIT	1
Single engagement vertical	PHE 50GCVRSB	1	PHE 50GCVCOVER	1	PHE 50GCKIT	1	50GCVCTRKIT	–
	PHE 50GCSERSB	1	–	–	–	–	–	–
Single engagement vertical floating	PHE 50GCVRSB	1	PHE 50GCVCOVER	1	PHE 50GCKIT	2	50GCVCTRKIT	2
	PHE 50GCFERSB	1	–	–	–	–	–	–
	PHE 50GCVRSB	1	PHE 50GCVCOVER	1	PHE 50GCKIT	2	PHE 50GCFSHAFT .. MM	1
	PHE 50GCSERSB	1	–	–	–	–	–	–
Rigid flanged sleeve	PHE 50GCRRSB	2	–	–	PHE 50GCRKIT	1	–	–
Size 80 and above	PHE 80GCRRSB	2	–	–	PHE 80GCRKIT	1	PHE 80GCRRING	1

A complete gear coupling consists of: 2 hubs, 2 covers and 1 assembly kit.
Coupling size 80 and above consists of: 2 hubs, 1 male cover, 1 female cover and 1 assembly kit.
For bored to size designations, add bore size RSB. For example: PHE 50GCX500MM.
For shrouded bolt covers, use cover number, e.g. PHE 50SGCCOVER and PHE 50SGCKIT for the assembly kit.
The assembly kit includes oil seals, gasket, bolts and lock-nuts.

Gear couplings

Double engagement

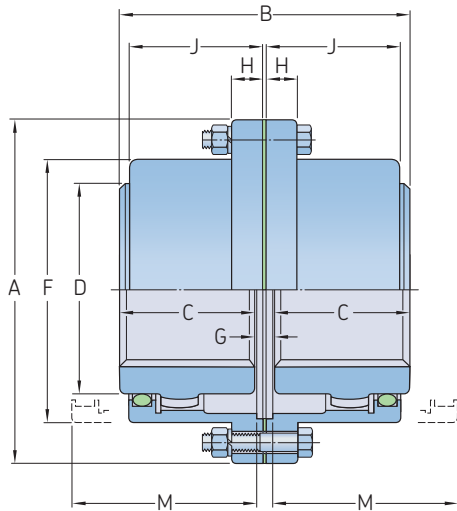

Size 10 to 70

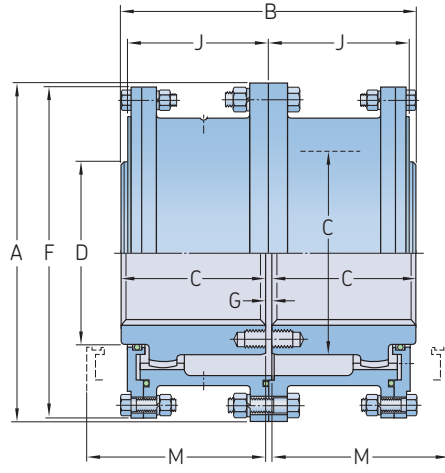

Size 80 to 120

Size	Power per 100 r/min	Rated torque	Speed	Bore diameter		Dimensions								Gap	Lubricant mass	Coupling mass without bore and min. DBSE
				Max.	Min.	A	B	C	D	F	H	J	M ¹⁾			
–	kW	Nm	r/min	mm	mm	mm	mm	mm	mm	mm	mm	mm	mm	mm	kg	
10 GC	11,9	1 139	8 000	13	50	116	89	43	69	84	14,0	39	51	3	0,04	5
15 GC	24,6	2 350	6 500	20	65	152	101	49	86	105	19,0	48	61	3	0,07	9
20 GC	44,7	4 270	5 600	26	78	178	127	62	105	126	19,0	59	77	3	0,12	16
25 GC	78,3	7 474	5 000	32	98	213	159	77	131	155	21,8	72	92	5	0,23	29
30 GC	127,0	12 100	4 400	39	111	240	187	91	152	180	21,8	84	107	5	0,36	43
35 GC	194,0	18 500	3 900	51	134	279	218	106	178	211	28,4	98	130	6	0,54	68
40 GC	321,0	30 609	3 600	64	160	318	248	121	210	245	28,4	111	145	6	0,91	97
45 GC	440,0	42 000	3 200	77	183	346	278	135	235	274	28,4	123	166	8	1,04	136
50 GC	593,0	56 600	2 900	89	200	389	314	153	254	306	38,1	141	183	8	1,77	190
55 GC	775,0	74 030	2 650	102	220	425	344	168	279	334	38,1	158	204	8	2,22	249
60 GC	947,0	90 400	2 450	115	244	457	384	188	305	366	25,4	169	229	8	3,18	306
70 GC	1 420,0	135 000	2 150	127	289	527	452	221	343	425	28,4	196	267	10	4,35	485
80 GC	1 780,0	170 000	1 750	102	266	591	508	249	356	572	–	243	300	10	9,53	703
90 GC	2 360,0	226 000	1 550	115	290	660	565	276	394	641	–	265	327	13	12,25	984
100 GC	3 250,0	310 000	1 450	127	320	711	623	305	445	699	–	294	356	13	14,97	1 302
110 GC	4 320,0	413 000	1 330	140	373	775	679	333	495	749	–	322	384	13	17,69	1 678
120 GC	5 810,0	555 000	1 200	153	400	838	719	353	546	826	–	341	403	13	20,87	2 114

¹⁾ Minimum clearance required for aligning coupling.

Gear couplings
Single engagement

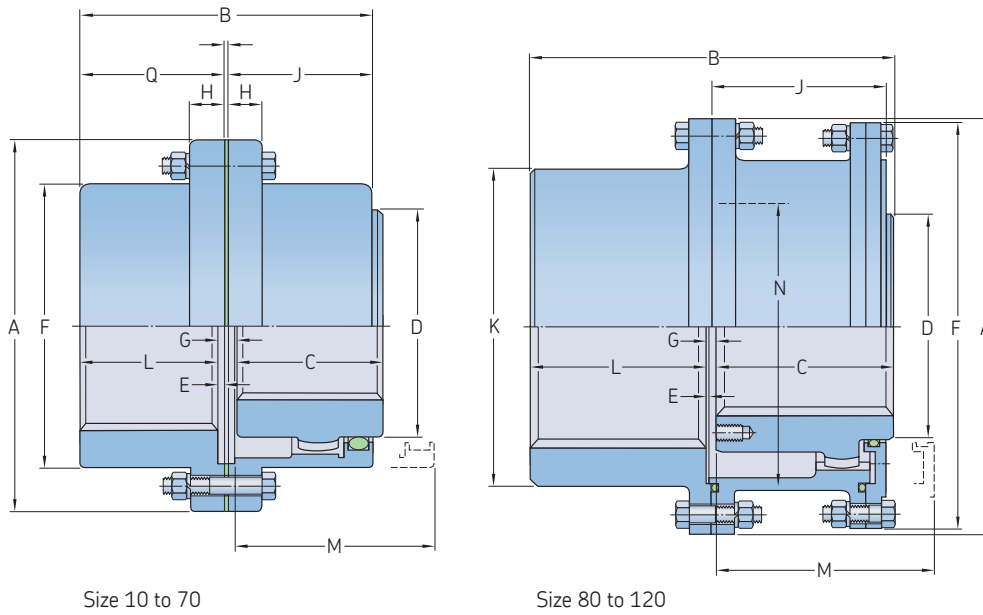

Size 10 to 70

Size 80 to 120

Size	Power per 100 r/min	Rated torque	Speed	Bore diameter			Dimensions											Gap	Lubricant mass	Coupling mass without bore	
				Flex hub	Se hub	Se hub	A	B	C	D	E	F	H	J	K ¹⁾	L	M ²⁾				Q
	kW	Nm	r/min	Max.	Max.	Min.	mm											mm	kg		
10 GCSE	11,9	1 139	8 000	48	60	13	116	87,0	43	69	2,5	84	14,0	39	-	40	51	42	4	0,02	4,5
15 GCSE	24,6	2 350	6 500	60	75	19	152	99,0	49	86	2,5	105	19,0	48	-	46	61	49	4	0,04	9,1
20 GCSE	44,7	4 270	5 600	73	92	25	178	124,0	62	105	2,5	126	19,0	59	-	58	77	61	4	0,07	15,9
25 GCSE	78,3	7 474	5 000	92	111	32	213	156,0	77	131	2,5	155	21,8	72	-	74	92	76	5	0,12	27,2
30 GCSE	127,0	12 100	4 400	105	130	38	240	184,0	91	152	2,5	180	21,8	84	-	88	107	90	5	0,18	43,1
35 GCSE	194,0	18 500	3 900	124	149	51	279	213,5	106	178	2,5	211	28,4	98	-	102	130	105	6	0,27	61,2
40 GCSE	321,0	30 609	3 600	146	171	64	318	243,0	121	210	4,1	245	28,4	111	-	115	145	119	7	0,47	99,8
45 GCSE	440,0	42 000	3 200	165	194	76	346	274,0	135	235	4,1	274	28,4	123	-	131	166	135	8	0,57	136,1
50 GCSE	593,0	56 600	2 900	178	222	89	389	309,0	153	254	5,1	306	38,1	141	-	147	183	152	9	0,91	195,0
55 GCSE	775,0	74 030	2 650	197	248	102	425	350,0	168	279	5,1	334	38,1	158	-	173	204	178	9	1,13	263,1
60 GCSE	947,0	90 400	2 450	222	267	114	457	384,0	188	305	6,6	366	25,4	169	-	186	229	193	10	1,70	324,3
70 GCSE	1 420,0	135 000	2 150	254	305	127	527	454,0	221	343	8,4	425	28,4	196	-	220	267	229	13	2,27	508,0
80 GCSE	1 780,0	170 000	1 750	279	343	102	591	511,0	249	356	-	572	-	243	450,8	249	300	-	13	4,99	698,5
90 GCSE	2 360,0	226 000	1 550	305	381	114	660	566,0	276	394	-	641	-	265	508,0	276	327	-	14	6,35	984,3
100 GCSE	3 250,0	310 000	1 450	343	406	127	711	626,0	305	445	-	699	-	294	530,4	305	356	-	16	7,71	1251,9
110 GCSE	4 320,0	413 000	1 330	387	445	140	775	682,0	333	495	-	749	-	322	584,2	333	384	-	16	9,07	1637,5
120 GCSE	5 810,0	555 000	1 200	425	495	152	838	722,0	353	546	-	826	-	341	647,7	353	403	-	16	10,89	2077,5

¹⁾ May be an "as cast" version depending on coupling size and bore.
²⁾ Minimum clearance required for aligning coupling.

Gear couplings

Double engagement · Spacer

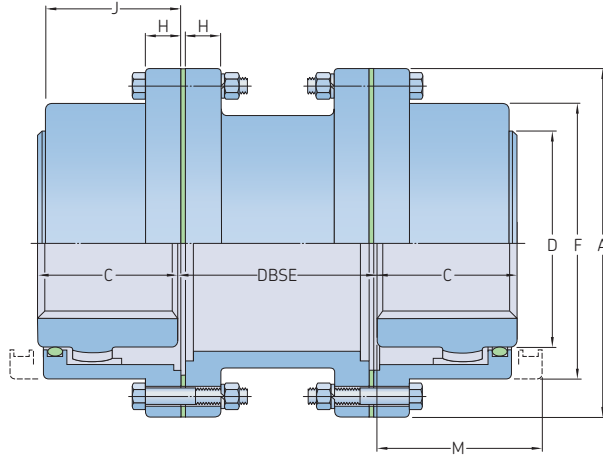

Size	Power per 100 r/min	Rated torque	Speed	DBSE		Bore diameter			Dimensions						Lubricant mass	Coupling mass without bore and min. bore
				Max.	Min.	Max.	Min.	Max.	A	C	D	F	H	J		
–	kW	Nm	r/min	mm											kg	
10 GCS	11,9	1 139	7 000	83	311	13	48	116	43	69	84	14,0	39	51	0,04	6,8
15 GCS	24,6	2 350	5 500	83	311	19	60	152	49	86	105	19,0	48	61	0,07	13,6
20 GCS	44,7	4 270	4 600	83	311	25	73	178	62	105	126	19,0	59	77	0,12	20,4
25 GCS	78,3	7 474	4 000	95	311	32	92	213	77	131	155	21,8	72	92	0,23	38,6
30 GCS	127,0	12 100	3 600	95	311	38	105	240	91	152	180	21,8	84	107	0,36	54,4
35 GCS	194,0	18 500	3 100	120	311	51	124	279	106	178	211	28,4	98	130	0,54	88,5
40 GCS	321,0	30 609	2 800	120	311	64	146	318	121	210	245	28,4	111	145	0,91	122,5
45 GCS	440,0	42 000	2 600	120	311	76	165	346	135	235	274	28,4	123	166	1,04	165,6
50 GCS	593,0	56 600	2 400	146	311	89	178	389	153	254	306	38,1	141	183	1,77	238,1
55 GCS	775,0	74 030	2 200	146	311	102	197	425	168	279	334	38,1	158	204	2,22	306,2
60 GCS	947,0	90 400	2 100	146	311	114	222	457	188	305	366	25,4	169	229	3,18	358,3
70 GCS	1 420,0	135 000	1 800	146	311	127	254	527	221	343	425	28,4	196	267	4,35	562,5

¹⁾ Minimum clearance required for aligning coupling.

Gear couplings

Double engagement · Vertical

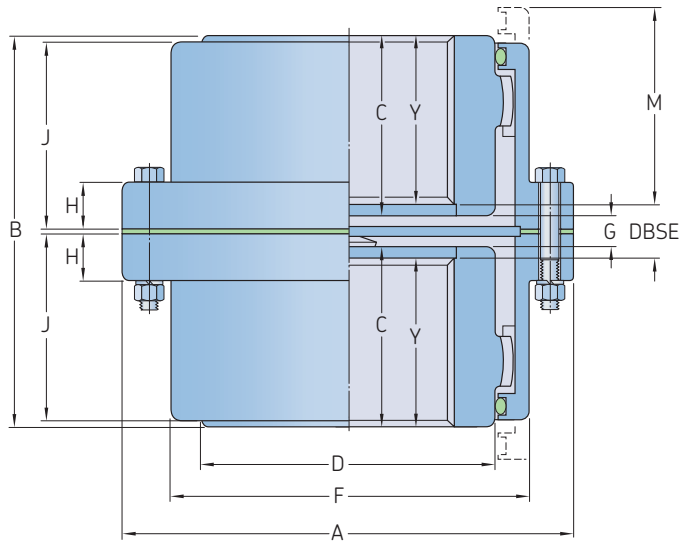

Size	Power per 100 r/min	Rated torque	Speed	Bore diameter		Dimensions										Gap	Lubricant mass	Coupling mass without bore
				Max.	Min.	A	B	C	D	F	H	J	M ¹⁾	Y	DBSE			
–	kW	Nm	r/min	mm	mm	mm										mm	kg	
10 GCV	11,9	1 139	8 000	13	48	116	89	43	69	84	14,0	39	51	32,5	24	11	0,04	5
15 GCV	24,6	2 350	6 500	19	60	152	101	49	86	105	19,0	48	61	38,6	24	11	0,07	9
20 GCV	44,7	4 270	5 600	25	73	178	127	62	105	126	19,0	59	77	51,3	24	11	0,12	16
25 GCV	78,3	7 474	5 000	32	92	213	159	77	131	155	21,8	72	92	65,3	26	14	0,23	29
30 GCV	127,0	12 100	4 400	38	105	240	187	91	152	180	21,8	84	107	79,8	26	14	0,36	43
35 GCV	194,0	18 500	3 900	51	124	279	218	106	178	211	28,4	98	130	94,0	30	18	0,54	68
40 GCV	321,0	30 609	3 600	64	146	318	248	121	210	245	28,4	111	145	105,9	35	22	0,91	97
45 GCV	440,0	42 000	3 200	76	165	346	278	135	235	274	28,4	123	166	116,3	44	25	1,04	136
50 GCV	593,0	56 600	2 900	89	178	389	314	153	254	306	38,1	141	183	134,6	44	25	1,77	190
55 GCV	775,0	74 030	2 650	102	197	425	344	168	279	334	38,1	158	204	149,6	44	25	2,22	249
60 GCV	947,0	90 400	2 450	114	222	457	384	188	305	366	25,4	169	229	168,1	48	29	3,18	306
70 GCV	1 420,0	135 000	2 150	127	254	527	452	221	343	425	28,4	196	267	194,8	61	35	4,35	485

¹⁾ Minimum clearance required for aligning coupling.

Gear couplings

Double engagement · Slide

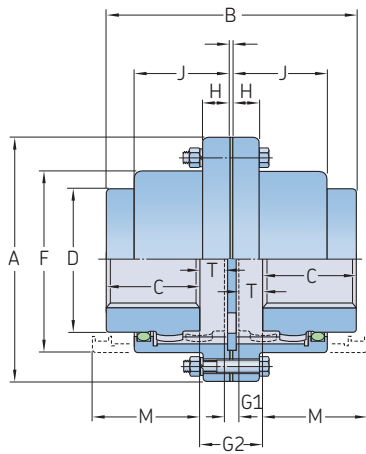

Type 1

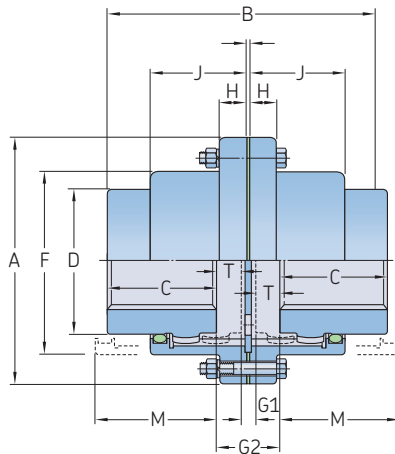

Type 2

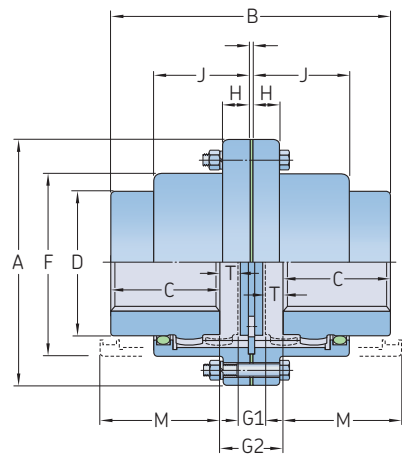

Type 3

Size	Power per 100 r/min	Rated torque	Speed	Dimensions		A	C	D	F	H	J	Lubricant mass	Coupling mass without bore
				Bore diameter									
			Max.	Min.	Max.	mm	mm	mm	mm	mm	mm	kg	
10 GCSL	11,9	1 139	5 300	13	48	116	43	69	84	14,0	39	0,02	5
15 GCSL	24,6	2 350	4 300	19	60	152	49	86	105	19,0	48	0,04	9
20 GCSL	44,7	4 270	3 700	25	73	178	62	105	126	19,0	59	0,06	16
25 GCSL	78,3	7 474	3 300	32	92	213	77	131	155	21,8	72	0,11	29
30 GCSL	127,0	12 100	2 900	38	105	240	91	152	180	21,8	84	0,18	43
35 GCSL	194,0	18 500	2 600	51	124	279	106	178	211	28,4	98	0,27	68
40 GCSL	321,0	30 609	2 400	64	146	318	121	210	245	28,4	111	0,45	97
45 GCSL	440,0	42 000	2 100	76	165	346	135	235	274	28,4	123	0,51	136
50 GCSL	593,0	56 600	1 900	89	178	389	153	254	306	38,1	141	0,91	190
55 GCSL	775,0	74 030	1 800	102	197	425	168	279	334	38,1	158	1,13	249
60 GCSL	947,0	90 400	1 600	114	222	457	188	305	366	25,4	169	1,19	306
70 GCSL	1 420,0	135 000	1 400	127	254	527	221	343	425	28,4	196	2,18	485

Size	Type 1						Type 2						Type 3					
	B Max.	M ¹⁾	Half T Max.	Total	Gap G ₁	G ₂	B Max.	M ¹⁾	Half T Max.	Total	Gap G ₁	G ₂	B Max.	M ¹⁾	Half T Max.	Total	Gap G ₁	G ₂
	mm						mm						mm					
10 GCSL	96	54	13	26	8	10	126	58	16	32	8	40	96	54	2,0	4	6	10
15 GCSL	127	60	10	20	8	29	152	69	23	46	8	54	127	60	7,5	15	14	29
20 GCSL	151	77	9	18	8	27	186	84	27	54	8	62	151	77	10,0	20	7	27
25 GCSL	188	93	12	24	9	34	231	102	34	68	9	78	188	93	6,0	12	21	34
30 GCSL	227	108	18	36	9	45	263	118	36	72	9	81	227	108	11,5	23	22	45
35 GCSL	274	124	25	50	11	61	313	135	45	90	11	102	274	124	14,0	28	33	61
40 GCSL	320	138	32	64	15	79	364	155	54	108	15	121	320	138	16,0	32	47	79
45 GCSL	355	154	35	70	16	86	406	163	60	120	16	136	355	154	19,0	38	47	86
50 GCSL	408	175	42	82	18	102	460	189	68	136	18	153	408	175	20,5	41	61	102
55 GCSL	470	191	58	116	18	134	510	221	78	156	18	174	470	191	21,0	42	92	134
60 GCSL	504	212	53	424	21	127	563	227	83	166	21	187	504	212	24,5	49	78	127
70 GCSL	592	245	62	490	26	150	669	235	99	198	26	223	592	245	27,0	54	96	150

¹⁾ Minimum clearance required for aligning coupling.

Gear couplings

Single engagement · Slide

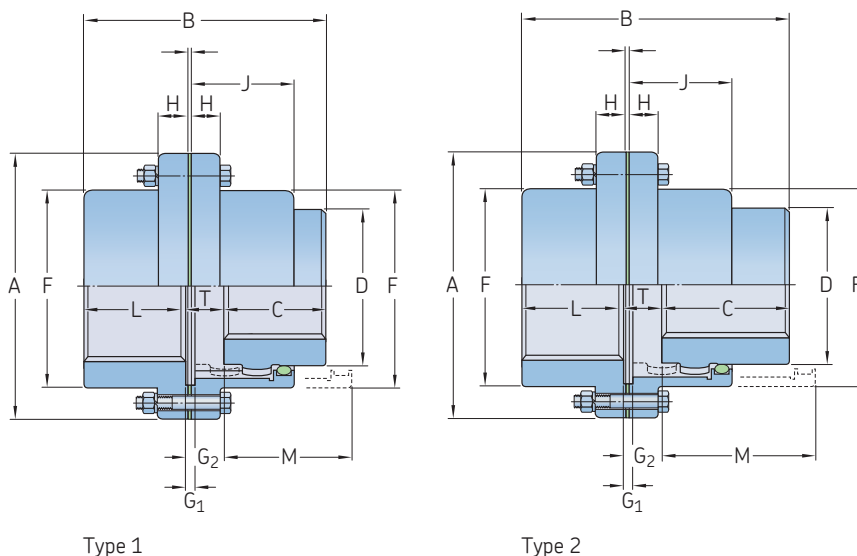

Size	Power per 100 r/min	Rated torque	Speed	Dimensions	Se hub	Dimensions								Lubricant mass	Coupling mass without bore	
						Bore diameter	Flex hub	A	C	D	F	H	J			L
			Max.	Max.	Max.	Min.	mm	mm	mm	mm	mm	mm	mm	mm	kg	kg
10 GCSL	11,9	1 139	5 300	48	60	13	116	43	69	84	14,0	39	40	0,01	5	
15 GCSL	24,6	2 350	4 300	60	75	19	152	49	86	105	19,0	48	46	0,02	9	
20 GCSL	44,7	4 270	3 700	73	92	25	178	62	105	126	19,0	59	58	0,04	16	
25 GCSL	78,3	7 474	3 300	92	111	32	213	77	131	155	21,8	72	74	0,06	29	
30 GCSL	127,0	12 100	2 900	105	130	38	240	91	152	180	21,8	84	88	0,11	43	
35 GCSL	194,0	18 500	2 600	124	149	51	279	106	178	211	28,4	98	102	0,18	68	
40 GCSL	321,0	30 609	2 400	146	171	64	318	121	210	245	28,4	111	115	0,27	97	
45 GCSL	440,0	42 000	2 100	165	194	76	346	135	235	274	28,4	123	131	0,34	136	
50 GCSL	593,0	56 600	1 900	178	222	89	389	153	254	306	38,1	141	147	0,54	195	
55 GCSL	775,0	74 030	1 800	197	248	102	425	168	279	334	38,1	158	173	0,73	263	
60 GCSL	947,0	90 400	1 600	222	267	114	457	188	305	366	25,4	169	186	0,96	324	
70 GCSL	1 420,0	135 000	1 400	254	305	127	527	221	343	425	28,4	196	220	1,36	510	

Size	Type 1					Type 2				
	B Max.	M ¹⁾	T Max.	Gap G ₁	G ₂	B Max.	M ¹⁾	T Max.	Gap G ₁	G ₂
	mm					mm				
10 GCSL	90,0	54	3,6	4	8	105	58	18,5	4	23
15 GCSL	112,0	60	12,7	4	17	125	69	25,4	4	30
20 GCSL	136,0	77	11,7	4	16	154	84	29,5	4	34
25 GCSL	170,0	93	14,5	5	19	192	102	36,3	5	41
30 GCSL	204,0	108	20,1	5	25	222	118	38,1	5	43
35 GCSL	241,0	124	27,2	6	33	262	135	47,8	6	53
40 GCSL	279,0	138	36,3	7	43	300	155	57,4	7	65
45 GCSL	315,0	154	38,9	8	47	338	163	64,0	8	72
50 GCSL	356,0	175	47,0	9	56	382	189	72,6	9	81
55 GCSL	412,5	191	63,0	9	72	433	221	83,1	9	92
60 GCSL	445,0	212	59,7	10	70	475	227	89,4	10	100
70 GCSL	524,0	245	70,4	13	83	560	235	106,7	13	119

¹⁾ Minimum clearance required for aligning coupling.

Gear couplings
Rigid flanged sleeve

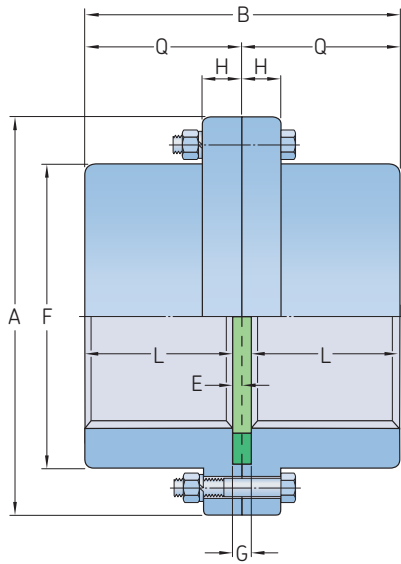

Size	Power per 100 r/min	Rated torque	Speed		Dimensions Bore diameter			Gap						Coupling mass without bore	
			Max.	Min.	Max.	A	B	E	F	H	L	Q	G		
–	kW	Nm	r/min	mm	mm	mm	mm	mm	mm	mm	mm	mm	mm	mm	kg
10 GCR	11,9	1 139	8 000	13	60	116	84,5	2,5	84	14,0	40,0	39	5	5	
15 GCR	24,6	2 350	6 500	19	75	152	97,5	2,5	105	19,0	46,0	48	5	9	
20 GCR	44,7	4 270	5 600	25	92	178	122,0	2,5	126	19,0	58,5	59	5	16	
25 GCR	78,3	7 474	5 000	32	111	213	152,5	2,5	155	21,8	73,5	72	5	28	
30 GCR	127,0	12 100	4 400	38	130	240	181,0	2,5	180	21,8	88,0	84	5	43	
35 GCR	194,0	18 500	3 900	51	149	279	209,0	2,5	211	28,4	102,0	98	5	68	
40 GCR	321,0	30 609	3 600	64	171	318	239,0	4,1	245	28,4	115,0	111	8	102	
45 GCR	440,0	42 000	3 200	76	194	346	269,0	4,1	274	28,4	130,5	123	8	140	
50 GCR	593,0	56 600	2 900	89	222	389	305,0	5,1	306	38,1	147,5	141	10	205	
55 GCR	775,0	74 030	2 650	102	248	425	355,5	5,1	334	38,1	172,5	158	10	280	
60 GCR	947,0	90 400	2 450	114	267	457	386,0	6,6	366	25,4	186,5	169	13	335	
70 GCR	1 420,0	135 000	2 150	127	305	527	457,0	8,4	425	28,4	220,0	196	17	536	
80 GCR	1 780,0	170 000	1 750	102	343	591	514,0	8,0	572	31,5	249,0	243	16	703	
90 GCR	2 360,0	226 000	1 550	114	381	660	568,0	8,0	641	38,0	276,0	265	16	984	
100 GCR	3 250,0	310 000	1 450	127	406	711	629,0	9,7	699	44,2	305,0	294	19	1 210	
110 GCR	4 320,0	413 000	1 330	140	445	775	686,0	9,7	749	50,8	333,0	322	19	1 610	
120 GCR	5 810,0	555 000	1 200	152	495	838	724,0	9,7	826	53,8	353,0	341	19	2 114	

Gear couplings

Single engagement · Vertical and floating shaft

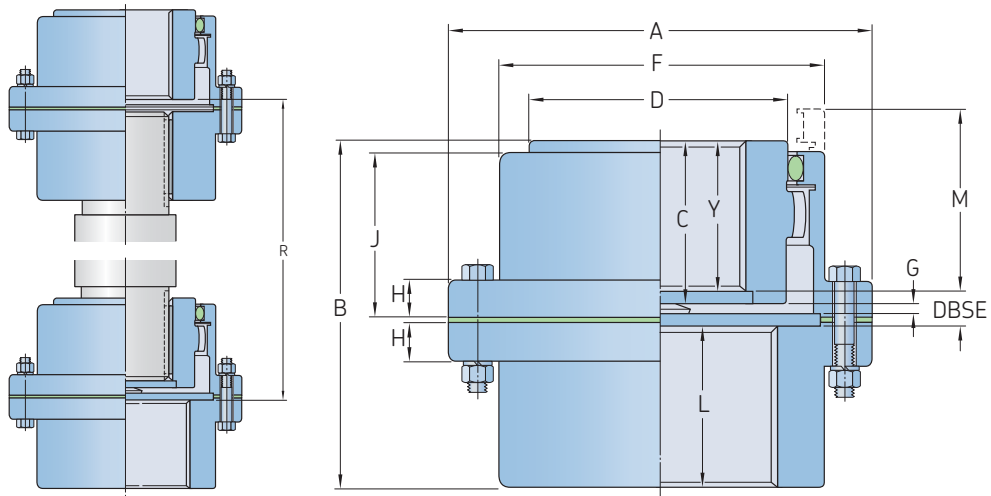

Size	Power per 100 r/min	Rated torque	Speed	Bore diameter			Dimensions											Gap		Lubricant mass	Coupling mass without bore
				Flex hub	Se hub		A	B	C	D	F	H	J	L	M	R	Y	DBSE	G		
	kW	Nm	r/min	Max.	Max.	Max.	Min.	mm											mm	kg	
10 GCV	11,9	1 139	7 000	48	60	13	116	87,0	43	69	84	14,0	39	40	51	132	32,5	14,7	4	0,02	4,5
15 GCV	24,6	2 350	5 500	60	75	19	152	99,0	49	86	105	19,0	48	46	61	152	38,6	14,7	4	0,04	9,1
20 GCV	44,7	4 270	4 600	73	92	25	178	124,0	62	105	126	19,0	59	58	77	183	51,3	14,7	4	0,07	15,9
25 GCV	78,3	7 474	4 000	92	111	32	213	156,0	77	131	155	21,8	72	74	92	218	65,3	16,3	5	0,12	27,2
30 GCV	127,0	12 100	3 600	105	130	38	240	184,0	91	152	180	21,8	84	88	107	248	79,8	16,3	5	0,18	43,1
35 GCV	194,0	18 500	3 100	124	149	51	279	213,5	106	178	211	28,4	98	102	130	298	94,0	18,0	6	0,27	61,2
40 GCV	321,0	30 609	2 800	146	171	64	318	243,0	121	210	245	28,4	111	115	145	340	105,9	22,0	7	0,47	99,8
45 GCV	440,0	42 000	2 600	165	194	76	346	274,0	135	235	274	28,4	123	131	166	388	116,3	26,7	8	0,57	136,1
50 GCV	593,0	56 600	2 400	178	222	89	389	309,0	153	254	306	38,1	141	147	183	424	134,6	27,7	9	0,91	195,0
55 GCV	775,0	74 030	2 200	197	248	102	425	350,0	168	279	334	38,1	158	173	204	464	149,6	27,7	9	1,13	263,1
60 GCV	947,0	90 400	2 100	222	267	114	457	384,0	188	305	366	25,4	169	186	229	522	168,1	30,9	10	1,70	324,3
70 GCV	1 420,0	135 000	1 800	254	305	127	527	454,0	221	343	425	28,4	196	220	267	615	194,8	39,1	13	2,27	508,0

Gear couplings

Single engagement · Floating shaft

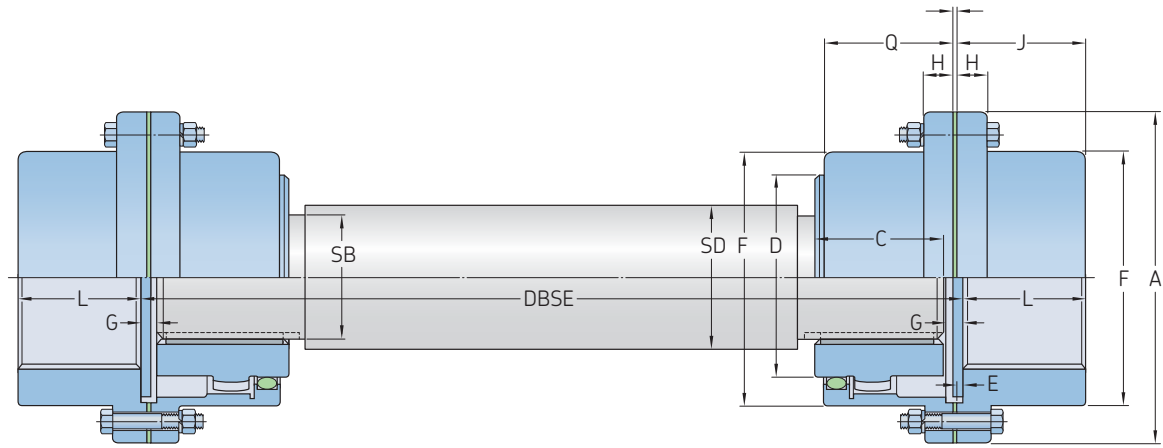

Flex hub on floating shaft

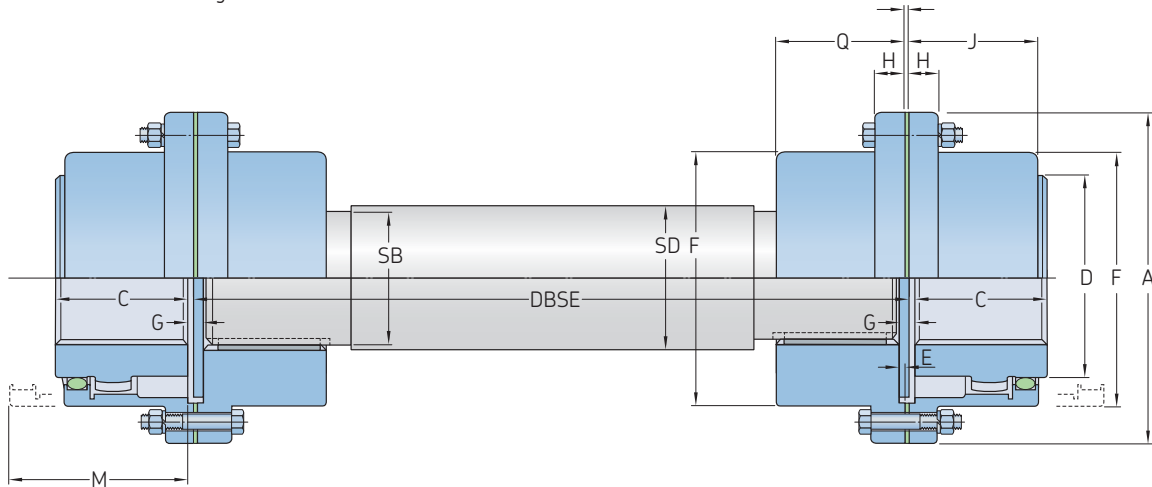

Rigid hubs on floating shaft

Size	DBSE		Bore diameter		Min.	Dimensions							Gap	Min lubricant mass	Coupling mass without bore	
	Flex hub	Rigid hub	Flex hub	Rigid hub		A	C	D	F	H	J	L				M
-	mm												kg			
10 GCFS	133	92	48	60	13	116	43	69	84	14,0	39	40	51	4	0,02	4,5
15 GCFS	159	105	60	75	19	152	49	86	105	19,0	48	46	61	4	0,04	9,1
20 GCFS	197	129	73	92	25	178	62	105	126	19,0	59	58	77	4	0,07	15,9
25 GCFS	241	162	92	111	32	213	77	131	155	21,8	72	74	92	5	0,12	27,2
30 GCFS	279	189	105	130	38	240	91	152	180	21,8	84	88	107	5	0,18	43,1
35 GCFS	324	219	124	149	51	279	106	178	211	28,4	98	102	130	6	0,27	61,2
40 GCFS	419	248	146	171	64	318	121	210	245	28,4	111	115	145	7	0,47	99,8
45 GCFS	508	281	165	194	76	346	135	235	274	28,4	123	131	166	8	0,57	136,1
50 GCFS	533	316	178	222	89	389	153	254	306	38,1	141	147	183	9	0,91	195,0
55 GCFS	572	367	197	248	102	425	168	279	334	38,1	158	173	204	9	1,13	263,1
60 GCFS	597	397	222	267	114	457	188	305	366	25,4	169	186	229	10	1,70	324,3
70 GCFS	673	470	254	305	127	527	221	343	425	28,4	196	220	267	13	2,27	508,0

Disc couplings

The SKF disc coupling is the ideal solution in medium to high torque applications that require torsional rigidity, offer some allowance for misalignment, and do not require lubrication. These applications typically have a capacity range up to 178 kNm in a range of configurations including single disc, double disc, and spacer for both horizontal and vertical mounting. Standard shaft capacities are up to 289 mm.

The SKF disc coupling consists of two hubs and a laminated stainless steel disc pack secured by a series of fitted bolts retained by nylon insert lock nut nuts.

For spacer units, the spacer length is held between two disc pack sets.

Single disc units can accommodate angular (α) offset only. Double disc pack units, with a spacer, will allow for angular (α), parallel (δ), or combined offset. Both configurations will also allow for some axial (δ) movement.

The disc pack, or spacer may be removed and re-installed radially, meaning the prime mover and driven machine need not be moved at all.

The all-steel machined components allow for high speed applications to be handled with ease. With two-plane dynamic balancing, higher speeds are often permissible.

Hubs are carried with pilot bores so that boring to requirements is easy. In addition, where zero backlash is required, the use of the SKF FX Keyless Bushing is a simple and economical solution.

The SKF Disc Coupling offers the following benefits:

- Medium to high torque capability
- Cost effective (v torque and size)
- No lubrication required
- No frictional or energy losses
- Quiet operation (no meshing)
- Zero backlash
- Angular misalignment (α^c)
- Parallel offset (β) with spacer / double disc pack configuration only
- High speed capability (may require dynamic balancing over 50 m/s)
- Limited end-float / axial movement (δ)

- Temperature-tolerant (generally up to 250 °C)
- Low inertia / mass MK^2 (when compared with other metallic-type couplings)
- Various hub designs, including short or inverted hub
- Standard spacer lengths to ANSI and ISO standards generally available
- Available with longer tubular spacers (steel or composite in some instances)
- Ease of mounting / alignment and maintenance

Coupling types

The SKF Disc Coupling is available in 2 basic configurations:

- Single disc
- Double disc
 - Short spacer
 - Standard spacer
 - Custom spacer
 - Floating horizontal
 - Floating vertical

Order data

Coupling type	Hubs		Disc pack		Bolt kit	Vertical kit	Spacer / Vertical kit (VKIT)					
–	Solid bore	Qty	Bored to size	Qty	Qty	Qty	Qty (... = DBSE dimension)	Qty				
Single-flex (W4)	PHE W4-15HUBRSB	2 or	PHE W4-15HUB...MM	2	PHE W4-15DPACK	1	PHE W4-15KIT	1	–	–		
Double-flex (W4), with spacer	PHE W4-15HUBRSB	2 or	PHE W4-15HUB...MM	2	PHE W4-15DPACK	2	PHE W4-15KIT	2	–	PHE W4-15X...MM	1	
Double-flex floating	PHE W6-35HUBRSB	2 or	PHE W6-35HUB...MM	2	PHE W6-35DPACK	2	PHE W6-35KIT	2	–	PHE W6-35FSX...MM	1	
Double-flex semi-floating	PHE W6-35HUBRSB	2 or	PHE W6-35HUB...MM	2	PHE W6-35DPACK	1	PHE W6-35KIT	1	–	PHE W6-35SFSSPX...MM	1	
Single-flex (vertical)	PHE W4-15HUBRSB	2 or	PHE W4-15HUB...MM	2	PHE W4-15DPACK	1	PHE W4-15KIT	1	PHE W4-15VKIT	1	–	
Double-flex (vertical) with spacer	PHE W6-35HUBRSB	2 or	PHE W6-35HUB...MM	2	PHE W6-35DPACK	2	PHE W6-35KIT	2	PHE W6-35VKIT	1	PHE W6-35X...MM	1
Double-flex floating (vertical)	PHE W6-35HUBRSB	2 or	PHE W6-35HUB...MM	2	PHE W6-35DPACK	2	PHE W6-35KIT	2	PHE W6-35VKIT	1	PHE W6-35FSX...MM	1

The complete coupling designation consists of the series, size and bore details. If bore is not specified, solid bore (RSB) is supplied, for example: PHE W6D-35x50MMx50MM or PHE W6D-45x350MMx50x50MM, where 350 mm is the required DBSE.

Unless specified, bore tolerance will be H7.

Option of taper bushing in the hub (mounting type F) is available on request. Note that coupling capacity may be reduced due to the taper bushing capacity. FX Keyless bushings are also an option in some cases. Please, refer to SKF for details on both options.

For bored to size designations, add bore size. For example: PHE W4D-45X50MMX45MM.

Disc couplings

W4 – 4 Bolt single

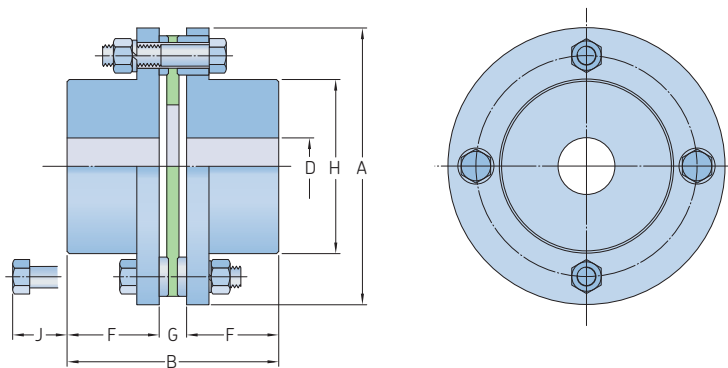

Size	Rated torque	Speed ¹⁾	Bore diameter		Dimensions						Tightening torque	Coupling weight without bore and min. DBSE
			D Min.	Max.	A	B	F	G	H	J		
–	Nm	r/min	mm								Nm	kg
05 S	34,3	10 000	8	23	67	55,8	25	5,8	33	16	9	0,6
10 S	90,0	10 000	10	32	81	57,1	25	7,1	46	16	9	1,1
15 S	176,0	10 000	10	35	93	66,4	29	8,4	51	24	22	1,7
20 S	245,0	10 000	10	42	104	79,0	34	11,0	61	30	22	2,5
25 S	421,0	8 300	16	50	126	93,2	41	11,2	71	27	41	4,3
30 S	774,0	7 300	16	58	143	108,5	48	12,5	84	28	72	6,9
35 S	1 274,0	6 200	25	74	168	130,0	57	16,0	106	26	72	11,3
40 S	2 058,0	5 400	25	83	194	145,0	64	17,0	118	30	160	16,7
45 S	3 332,0	4 900	45	95	214	174,8	76	22,8	137	34	160	22,7
50 S	4 900,0	4 200	50	109	246	202,0	89	24,0	156	26	220	35,4
55 S	6 370,0	3 800	50	118	276	230,0	102	26,0	169	42	570	52,0

¹⁾ If higher speed required, contact SKF

Disc couplings
W4 – 4 Bolt double

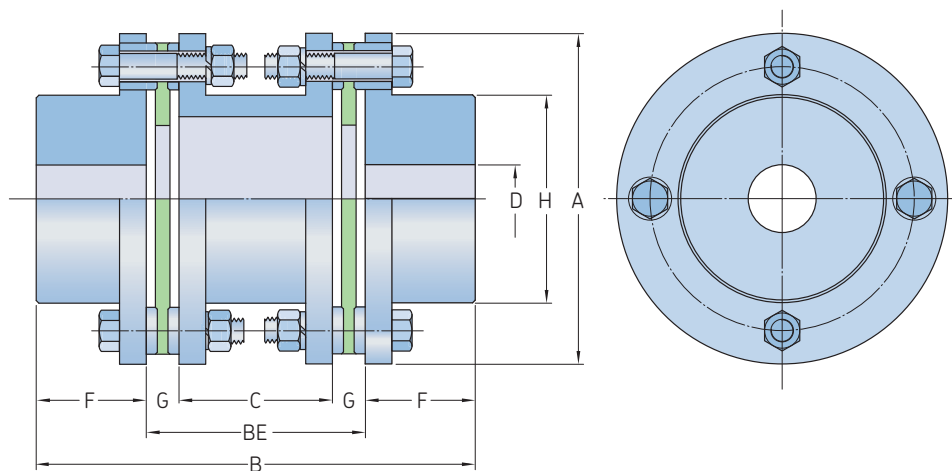

Size	Rated torque	Speed ¹⁾	Bore diameter		Dimensions								Tightening torque	Coupling weight without bore and min. DBSE
			D Min.	Max.	A	B	BE ³⁾ Min.	C ²⁾	F	G	H	J		
-	Nm	r/min	mm										Nm	kg
05 D	33,3	10 000	8	23	67	86,0	36,0	24	25	5,8	33	16	9	1,1
	33,3	10 000	8	23	67	138,9	88,9	77	25	5,8	33	16	9	1,2
10 D	90,2	10 000	10	32	81	89,0	39,0	25	25	7,1	46	16	9	1,7
	90,2	10 000	10	32	81	138,9	88,9	75	25	7,1	46	16	9	1,9
15 D	176,0	10 000	10	35	93	105,0	47,0	30	29	8,4	51	24	22	2,7
	176,0	10 000	10	35	93	159,6	101,6	85	29	8,4	51	24	22	2,9
20 D	245,0	10 000	10	42	104	121,0	53,0	31	34	11,0	61	30	22	6,6
	245,0	10 000	10	42	104	195,0	127,0	105	34	11,0	61	30	22	4,1
25 D	421,0	8 300	16	50	126	144,0	62,0	40	41	11,2	71	27	41	6,6
	421,0	8 300	16	50	126	209,0	127,0	105	41	11,2	71	27	41	7,1
30 D	774,0	7 300	16	58	143	165,0	69,0	44	48	12,5	84	28	72	10,3
	774,0	7 300	16	58	143	223,0	127,0	102	48	12,5	84	28	72	10,8
35 D	1 274,0	6 200	25	74	168	192,0	78,0	46	57	16,0	106	26	72	15,6
	1 274,0	6 200	25	74	168	241,0	127,0	95	57	16,0	106	26	72	16,3
40 D	2 058,0	5 400	25	83	194	217,0	89,0	55	64	17,0	118	30	160	24,0
	2 058,0	5 400	25	83	194	267,7	139,7	106	64	17,0	118	30	160	24,7
45 D	3 332,0	4 900	45	90	214	249,0	97,0	51	76	22,8	137	34	160	31,5
	3 332,0	4 900	45	90	214	304,4	152,4	107	76	22,8	137	34	160	32,5
50 D	4 900,0	4 200	50	109	246	287,0	109,0	61	89	24,0	156	26	220	48,4
	4 900,0	4 200	50	109	246	355,8	177,8	130	89	24,0	156	26	220	50,0
55 D	5 880,0	3 800	50	118	276	338,0	134,0	82	102	26,0	169	42	570	73,9
	5 880,0	3 800	50	118	276	381,8	177,8	126	102	26,0	169	42	570	75,0

¹⁾ If higher speed required, contact SKF

²⁾ For dimension C in type 4F, this varies depending on spacer length

³⁾ Preferred standard spacer lengths to both ISO and ANSI standards are available.

Disc couplings

W6 – 6 Bolt double

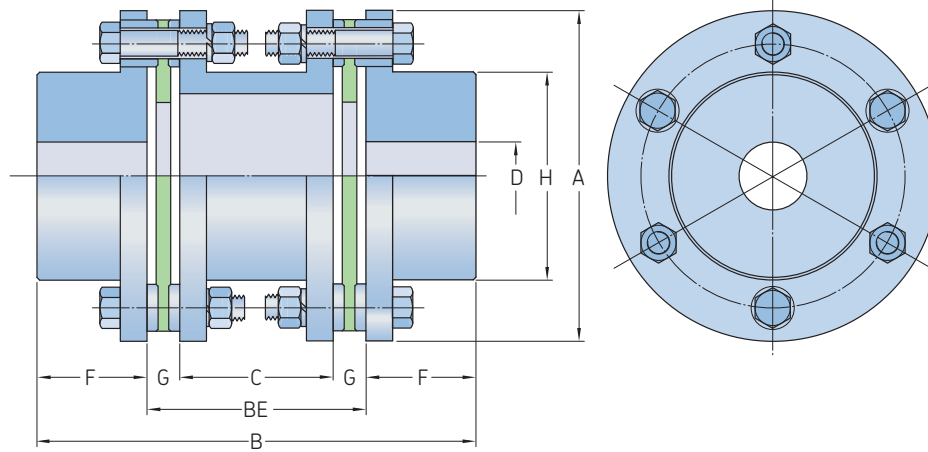

Size	Rated torque Speed ¹⁾		Bore diameter		Dimensions							Tightening torque	Coupling weight without bore and min. DBSE
	Nm	r/min	D Min.	Max.	A	B	BE ³⁾ Min.	C ²⁾	F	G	H		
00 D	569	26 000	8	51	119	168	60	39,4	54	10,3	74	22	6,0
01 D	922	23 000	8	55	137	198	72	50,0	63	11,0	81	41	9,1
02 D	1 710	19 000	8	67	161	238	90	66,0	74	12,0	97	72	16,9
03 D	3 340	17 000	8	72	180	269	109	81,0	80	14,0	104	160	21,6
04 D	6 210	15 000	8	85	212	308	118	84,0	95	17,0	124	220	35,1
05 D	6 080	11 600	8	111	276	377	153	118,0	112	17,5	161	220	65,1
10 D	8 240	11 600	10	111	276	377	153	115,0	112	19,0	161	220	66,1
15 D	10 700	10 300	10	133	308	440	172	134,0	134	19,0	193	440	107,8
20 D	17 800	9 200	10	152	346	497	191	146,0	153	22,5	218	570	156,8
25 D	26 400	8 500	16	165	375	553	223	167,0	165	28,0	240	1 100	211,8
30 D	33 400	7 800	16	178	410	610	254	192,0	178	31,0	258	1 500	274,8
35 D	39 900	7 200	25	187	445	646	270	208,0	188	31,0	272	1 700	333,0
40 D	46 300	6 800	25	205	470	686	274	206,0	206	34,0	297	1 700	400,0
45 D	59 800	6 200	45	231	511	749	287	216,0	231	35,5	334	1 700	525,0
50 D	74 700	5 700	50	254	556	800	292	218,0	254	37,0	364	3 000	676,0
55 D	92 600	5 400	50	263	587	839	311	236,0	364	37,5	382	3 500	803,0
60 D	107 000	5 000	50	275	629	895	343	268,0	276	37,5	399	3 700	654,0
65 D	128 000	4 800	50	289	654	934	356	281,0	289	37,5	419	4 000	1095,0

¹⁾ If higher speed required, contact SKF

²⁾ For dimensions B, C in type 6F, this varies depending on spacer length

³⁾ Preferred standard spacer lengths to both ISO and ANSI standards are available.

Disc couplings

W8 – 8 Bolt double

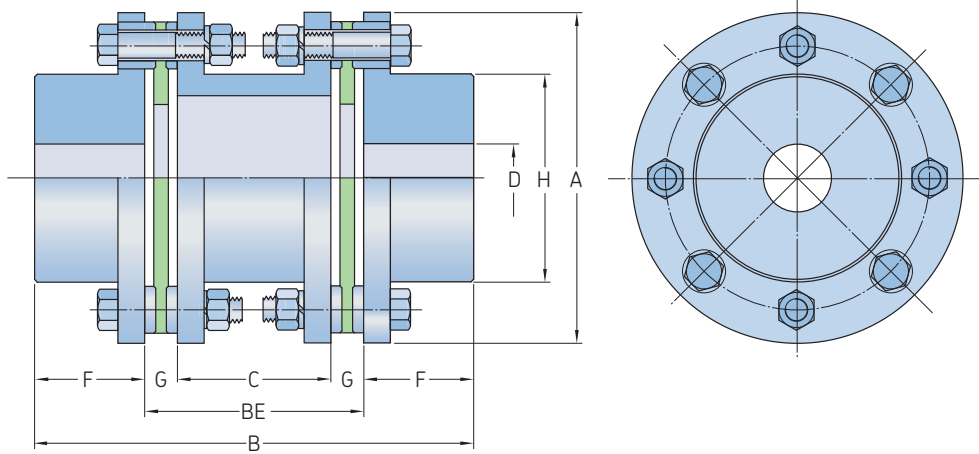

Size	Rated torque Speed ¹⁾		Bore diameter		Dimensions							Tightening torque	Coupling weight without bore and min. DBSE ³⁾
	Nm	r/min	D Min.	Max.	A	B ²⁾	BE ^{4) 5)}	C ²⁾	F	G	H		
–	Nm	r/min	mm									Nm	kg
01 D	3 840	15 000	8	95	214	333	117	92,6	108	12,2	137	72	38
03 D	7 120	13 000	8	108	246	369	127	99,6	121	13,7	156	160	56
05 D	8 970	11 600	8	111	276	421	153	118,0	134	17,5	161	220	73
10 D	11 800	11 600	10	111	276	421	153	115,0	134	19,0	161	220	74
15 D	15 400	10 300	10	133	308	492	172	134,0	160	19,0	193	440	120
20 D	25 600	9 200	10	152	346	557	191	148,0	183	21,5	218	570	175
25 D	37 800	8 500	16	165	375	619	223	175,0	198	24,0	240	1 100	234
30 D	47 800	7 800	16	178	410	682	254	195,0	214	29,5	258	1 500	305
35 D	57 100	7 200	25	187	445	720	270	211,0	225	29,5	272	1 700	368
40 D	64 400	6 800	25	205	470	768	274	212,0	247	31,0	297	1 700	448
45 D	83 700	6 200	45	231	511	843	287	223,0	278	32,0	334	1 700	592
50 D	103 000	5 700	50	254	556	902	292	227,0	305	32,5	364	3 000	762
55 D	128 000	5 400	50	263	587	945	311	243,0	317	34,0	382	3 500	902
60 D	149 000	5 000	50	275	629	1005	343	274,0	331	34,5	399	3 700	1068
65 D	178 000	4 800	50	289	654	1050	356	285,0	347	35,5	419	4 000	1231

¹⁾ If higher speed required, contact SKF.

²⁾ For dimension B, C in type 6F, this varies depending on spacer length.

³⁾ For coupling weight in type 4F, this varies depending on spacer length.

⁴⁾ Maximum permissible Be will be determined and limited by operating speed.

⁵⁾ Preferred standard spacer lengths to both ISO and ANSI standards are available.

Floating shaft disc couplings

SKF Floating shaft disc couplings transmit power between widely separated machine shafts, or where large parallel misalignment exists.

Allowable rotational speeds are determined, and limited, by the span and the balance condition of the coupling system. Balancing is necessary for high speeds and long shafts as indicated in the following tables 1 to 3.

Disc floating shaft couplings are also available for vertical applications with the addition of a vertical floating shaft kit.

- 1 Do not use floating shaft couplings with long, overhanging shafts.
- 2 Consult SKF for spans greater than 6 000 mm, or for speeds in excess of those indicated in the tables.

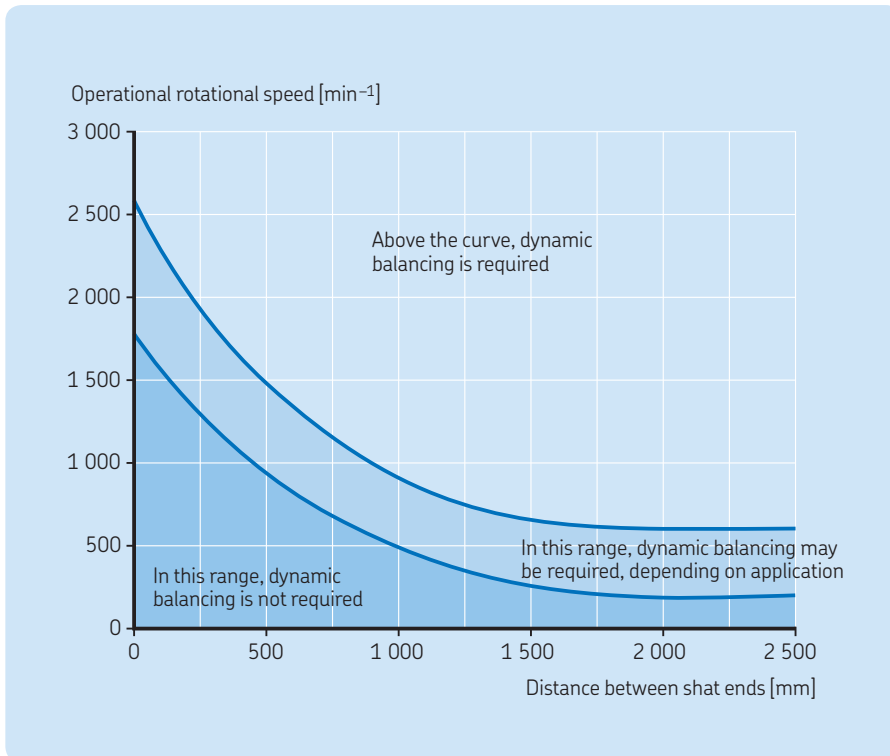

W4F Speed

Size	Bore Max. r/min	Maximum distance between shaft ends (BE max) for various speeds								
		1 800	1 500	1 200	1 000	900	750	720	600	500
010	32	1 610	1 760	1 970	2 160	2 280	2 500	2 550	2 790	3 060
015	35	1 690	1 850	2 070	2 270	2 390	2 620	2 670	2 930	3 210
020	42	1 880	2 050	2 300	2 520	2 650	2 910	2 970	3 250	3 560
025	50	2 010	2 210	2 470	2 700	2 850	3 120	3 190	3 490	3 830
030	58	2 220	2 430	2 720	2 980	3 140	3 440	3 510	3 850	4 210
035	74	2 500	2 740	3 060	3 350	3 540	3 870	3 950	4 330	4 750
040	83	2 690	2 950	3 300	3 610	3 800	4 180	4 250	4 660	5 120
045	95	2 890	3 170	3 540	3 880	4 090	4 490	4 570	5 010	5 500
050	109	3 100	3 400	3 800	4 160	4 390	4 820	4 910	5 370	5 900
055	118	3 230	3 540	3 960	4 330	4 560	5 010	5 100	5 590	–

For BE dimensions over 6 000 mm, please contact SKF
Floating shaft couplings should not be used with long overhang shafts

Floating shaft disc couplings

W6F Speed

Size	Bore	Maximum distance between shaft ends (BE max) for various speeds								
		1 800	1 500	1 200	1 000	900	750	720	600	500
Max.										
–	r/min	r/min								
000	51	2 010	2 210	2 470	2 700	2 850	3 120	3 190	3 490	3 830
001	55	2 220	2 430	2 720	2 980	3 140	3 440	3 510	3 850	4 210
002	67	2 500	2 740	3 060	3 350	3 540	3 870	3 950	4 330	4 750
003	72	2 890	3 170	3 540	3 880	4 090	4 490	4 570	5 010	5 500
004	85	3 100	3 400	3 800	4 160	4 390	4 820	4 910	5 370	5 900
005	111	3 100	3 400	3 800	4 160	4 390	4 820	4 910	5 370	5 900
010	111	3 100	3 540	3 800	4 160	4 390	4 820	4 910	5 370	5 900
015	133	3 230	3 540	3 960	4 330	4 560	5 010	5 100	5 590	–
020	152	3 720	4 070	4 560	4 990	5 250	5 770	5 880	–	–
025	165	3 720	4 070	4 560	4 990	5 250	5 770	5 880	–	–
030	178	3 860	4 030	4 510	4 940	5 200	5 710	5 810	–	–
035	187	4 140	4 540	5 070	5 560	5 850	–	–	–	–
040	205	4 140	4 540	5 070	5 560	5 850	–	–	–	–
045	231	4 530	4 960	5 540	–	–	–	–	–	–
050	254	4 790	5 240	5 860	–	–	–	–	–	–
055	263	4 790	5 240	5 860	–	–	–	–	–	–
060	275	4 790	5 240	5 860	–	–	–	–	–	–
065	289	5 120	5 600	–	–	–	–	–	–	–

For BE dimensions over 6 000 mm, please contact SKF
Floating shaft couplings should not be used with long overhang shafts

W8F Speed

Size	Bore	Maximum distance between shaft ends (BE max) for various speeds								
		1 800	1 500	1 200	1 000	900	750	720	600	500
Max.										
–	r/min	r/min								
001	95	2 890	3 170	3 540	3 880	4 090	4 490	4 570	5 010	5 500
003	108	3 100	3 400	3 800	4 160	4 390	4 820	4 910	5 370	5 900
005	111	3 100	3 400	3 800	4 160	4 390	4 820	4 910	5 370	5 900
010	111	3 100	3 400	3 800	4 160	4 390	4 820	4 910	5 370	5 900
015	133	3 230	3 450	3 960	4 330	4 560	5 010	5 100	5 590	–
020	152	3 720	4 070	4 560	4 990	5 250	5 770	5 880	–	–
025	165	3 680	4 030	4 510	4 940	5 200	5 710	5 810	–	–
030	178	3 680	4 030	4 510	4 940	5 200	5 710	5 810	–	–
035	187	4 100	4 490	5 020	5 500	5 790	–	–	–	–
040	205	4 100	4 490	5 020	5 500	5 790	–	–	–	–
045	231	4 480	4 900	5 480	6 010	–	–	–	–	–
050	254	4 730	5 180	5 800	–	–	–	–	–	–
055	263	4 730	5 180	5 800	–	–	–	–	–	–
060	275	4 730	5 180	5 800	–	–	–	–	–	–
065	289	5 060	5 540	–	–	–	–	–	–	–

For BE dimensions over 6 000 mm, please contact SKF
Floating shaft couplings should not be used with long overhang shafts

Disc couplings

W4 FH – Floating shaft

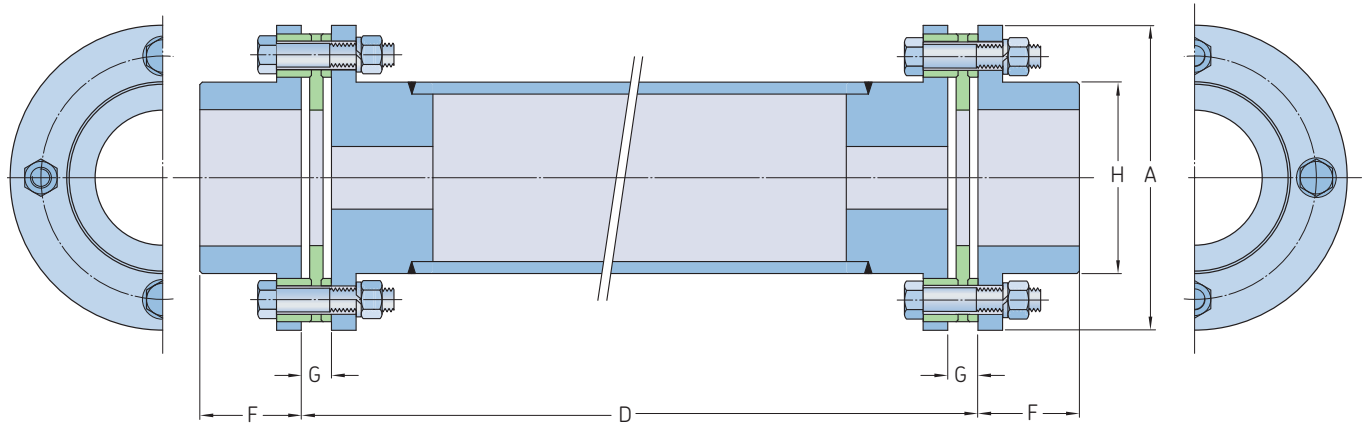

Size	Rated torque ²⁾	Speed ¹⁾ Max.	Bore diameter		Dimensions						Tightening torque	Coupling weight without bore and min. DBSE	
			D Min.	Max.	A	BE ³⁾ Min.	F	G	H	J			C
		Nm	r/min	mm								Nm	kg
10 FH	90,2	10 000	10	32	81	72	25	7,1	46	16	Dimension varies on BE required	9	Weight varies on length of spacer C
15 FH	176,0	10 000	10	35	93	76	29	8,4	51	24		22	
20 FH	245,0	10 000	10	42	104	88	34	11,0	61	30		22	
25 FH	421,0	8 300	16	50	126	99	41	11,2	71	27	41		
30 FH	774,0	7 300	16	58	143	111	48	12,5	84	28	72		
35 FH	1 274,0	6 200	25	74	168	142	57	16,0	106	26	72		
40 FH	2 058,0	5 400	25	83	194	154	64	17,0	118	30	160		
45 FH	3 332,0	4 900	45	90	214	183	76	22,8	137	34	160		
50 FH	4 900,0	4 200	50	109	246	211	89	24,0	156	26	220		
55 FH	5 880,0	3 800	50	118	276	234	102	26,0	169	42	570		

¹⁾ Maximum rotational speed (r/min) is based on parallel misalignment no more than 2/1 000

²⁾ Rated torque is a maximum figure

³⁾ For BE dimensions over 6 000 mm, please contact SKF

Disc couplings

W6 FH – Floating shaft

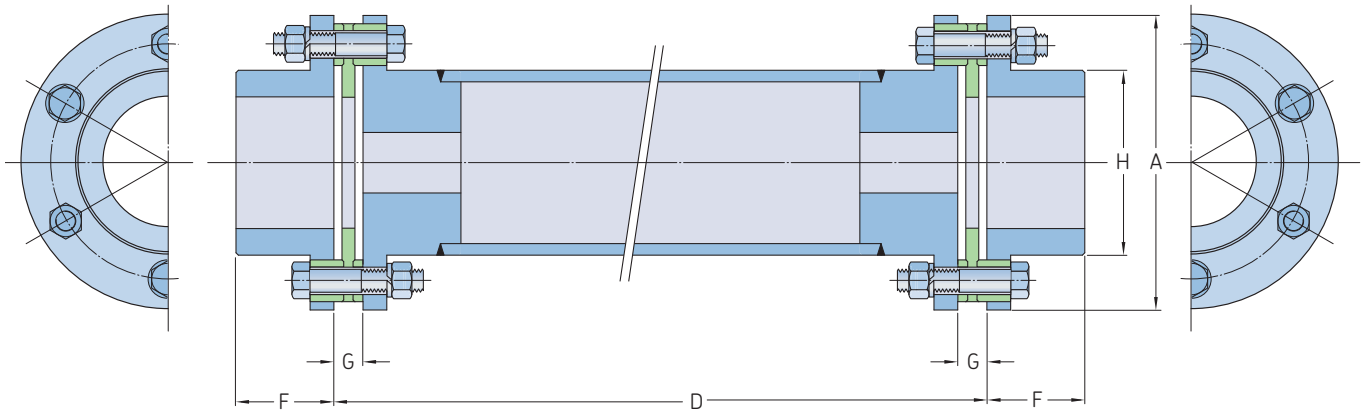

Size	Rated torque ²⁾	Speed ¹⁾	Bore diameter		Dimensions					Tightening torque	Coupling weight without bore and min. DBSE
			D Min.	Max.	A	BE	F	G	H		
	Nm	r/min	mm							Nm	kg
00 FH	569	26 000	8	51	119	60	54	10,3	74	22	6,0
01 FH	922	23 000	8	55	137	72	63	11,0	81	41	9,1
02 FH	1 710	19 000	8	67	161	90	74	12,0	97	72	16,9
03 FH	3 340	17 000	8	72	180	109	80	14,0	104	160	21,6
04 FH	6 210	15 000	8	85	212	118	95	17,0	124	220	35,1
05 FH	6 080	11 600	8	111	276	153	112	17,5	161	220	65,1
10 FH	8 240	11 600	10	111	276	153	112	19,0	161	220	66,1
15 FH	10 700	10 300	10	133	308	172	134	19,0	193	440	107,8
20 FH	17 800	9 200	10	152	346	191	153	22,5	218	570	156,1
25 FH	26 400	8 500	16	165	375	223	165	28,0	240	1 100	211,8
30 FH	33 400	7 800	16	178	410	254	178	31,0	258	1 500	274,5
35 FH	39 900	7 200	25	187	445	270	188	31,0	272	1 700	333,3
40 FH	46 300	6 800	25	205	470	274	206	34,0	297	1 700	399,2
45 FH	59 800	6 200	45	231	511	287	231	35,5	334	1 700	525,3
50 FH	74 700	5 700	50	254	556	292	254	37,0	364	3 000	676,3
55 FH	92 600	5 400	50	263	587	311	263	37,5	382	3 500	803,4
60 FH	107 000	5 000	50	275	629	343	231	37,5	399	3 700	954,1
65 FH	128 000	4 800	50	289	654	356	254	37,5	419	4 000	1 095,3

¹⁾ Maximum rotational speed (r/min) is based on parallel misalignment no more than 2/1 000
²⁾ Rated torque is a maximum figure

Disc couplings

W8 FH – Floating shaft

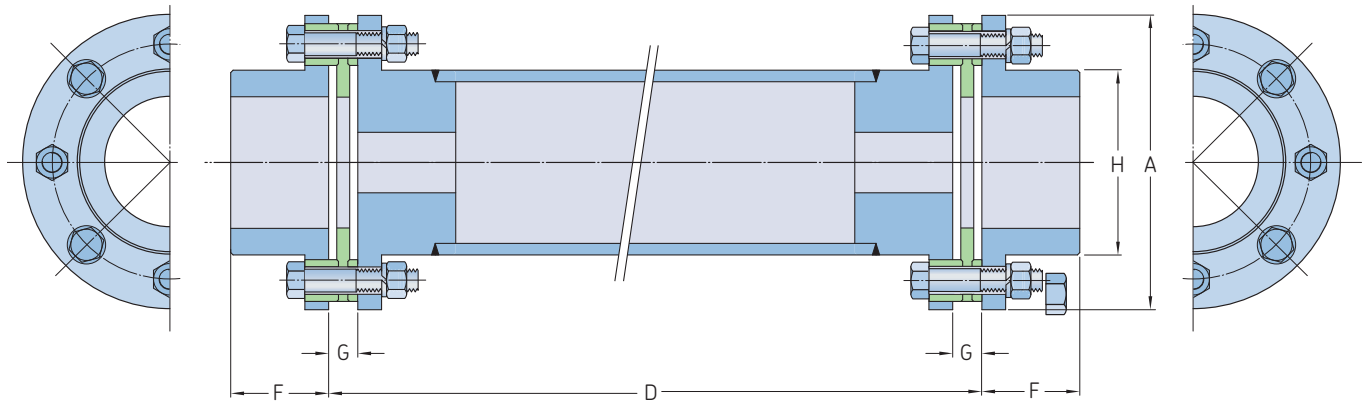

Size	Rated torque ²⁾	Speed ¹⁾	Bore diameter		Dimensions					Tightening torque	Coupling weight without bore and min. DBSE
			D Min.	Max.	A	BE ⁴⁾	F	G	H		
	Nm	r/min	mm							Nm	kg
01FH	3 840	15 000	8	51	119	240	54	10,3	74	22	6,0
03FH	7 120	13 000	8	55	137	269	63	11,0	81	41	9,1
05FH	8 970	11 600	8	67	161	255	74	12,0	97	72	16,9
10FH	11 800	11 600	8	72	180	258	80	14,0	104	160	21,6
15FH	15 400	10 300	8	85	212	278	95	17,0	124	220	35,1
20FH	25 600	9 200	10	111	276	283	112	17,5	161	220	65,1
25FH	37 800	8 500	16	111	276	308	112	19,0	161	220	66,1
30FH	47 800	7 800	16	133	308	319	134	19,0	193	440	107,8
35FH	57 100	7 200	25	152	346	339	153	22,5	218	570	156,1
40FH	64 400	6 800	25	165	375	342	165	28,0	240	1 100	211,8
45FH	83 700	6 200	45	178	410	364	178	31,0	258	1 500	274,5
50FH	103 000	5 700	50	187	445	365	188	31,0	272	1 700	333,3
55FH	128 000	5 400	50	205	470	408	206	34,0	297	1 700	399,2
60FH	149 000	5 000	50	231	511	— ³⁾	231	35,5	334	1 700	525,3
65FH	178 000	4 800	50	254	556	— ³⁾	254	37,0	364	3 000	676,3

¹⁾ Maximum rotational speed (r/min) is based on parallel misalignment no more than 2/1 000

²⁾ Rated torque is a maximum figure

³⁾ The actual BE value will be determined by the customer

⁴⁾ For BE dimensions over 6 000 mm, please contact SKF

Floating shaft couplings should not be used with long overhang shafts

SKF Flex couplings

SKF Flex couplings are designed to accommodate misalignment and shock loads and dampen vibration levels. These easy to install, maintenance-free couplings are available with either a machined-to-size or tapered bore.

Couplings with a tapered bore can be Face (F) mounted or Hub (H) mounted. The more versatile Reversible (R) design can be either face or hub mounted depending on the application. These couplings are also available with a tapered bushing.

SKF Flex couplings consist of 2 flanges and 1 tyre. The flanges are phosphate coated for improved corrosion resistance. The addition of a standard sized spacer flange can be used to accommodate applications where it is advantageous to move either shaft axially without disturbing driving or driven machines.

SKF Flex tyres are available in natural rubber compounds for applications ranging from -50 to +50 °C. Chloroprene rubber compounds should be used in applications where exposure to greases and oils are likely. These compounds can accommodate temperatures ranging from -15 to +70 °C. The chloroprene tyres should be used where fire-resistance and anti-static (F.R.A.S.) properties are required.

Assembled coupling characteristics

Coupling size	Maximum speed	Mass tyre	Inertia	Torsional stiffness	Misalignment			Nominal torque	Max torque	Screw size	Clamping screw torque
					Angular	Parallel	Axial				
–	r/min	kg	kg/m ²	Nm/°	°	mm		Nm	–	Nm	
40	4 500	0,1	0,00074	5	4	1,1	1,3	24	64	M6	15
50	4 500	0,3	0,00115	13	4	1,3	1,7	66	160	M6	15
60	4 000	0,5	0,0052	26	4	1,6	2,0	127	318	M6	15
70	3 600	0,7	0,009	41	4	1,9	2,3	250	487	M8	24
80	3 100	1,0	0,017	63	4	2,1	2,6	375	759	M8	24
90	3 000	1,1	0,031	91	4	2,4	3,0	500	1 096	M10	40
100	2 600	1,1	0,054	126	4	2,6	3,3	675	1 517	M10	40
110	2 300	1,4	0,078	178	4	2,9	3,7	875	2 137	M10	40
120	2 050	2,3	0,013	296	4	3,2	4,0	1 330	3 547	M12	50
140	1 800	2,6	0,255	470	4	3,7	4,6	2 325	5 642	M12	55
160	1 600	3,4	0,38	778	4	4,2	5,3	3 770	9 339	M16	80
180	1 500	7,7	0,847	1 371	4	4,8	6,0	6 270	16 455	M16	105
200	1 300	8,0	1,281	1 959	4	5,3	6,6	9 325	23 508	M16	120
220	1 100	10,0	2,104	2 760	4	5,8	7,3	11 600	33 125	M20	165
250	1 000	15,0	3,505	3 562	4	6,6	8,2	14 675	42 740	M20	165

Order data

Coupling type	Flanges	Qty	Element	Qty	Coupling bushing number	Qty	Spacer flange and shaft ¹⁾	Qty	Spacer bushing number	Qty
RSB both sides	PHE F70RSBFLG	2	PHE F70NRTYRE or	1	–	–	–	–	–	–
	–	–	PHE F70FRTYRE	–	–	–	–	–	–	–
RSB/F combination	PHE F70RSBFLG	1	PHE F70NRTYRE or	1	–	–	–	–	–	–
	PHE F70FTBFLG	1	PHE F70FRTYRE	–	PHF TB2012X...MM	1	PHE SM25...DBSE	1	PHF 2517X...MM	1
RSB/H combination	PHE F70RSBFLG	1	PHE F70NRTYRE or	1	–	–	–	–	–	–
	PHE F70HTBFLG	1	PHE F70FRTYRE	–	PHF TB1610X...MM	1	PHE SM25...DBSE	1	PHF 2517X...MM	1
F/F combination	PHE F70FTBFLG	1	PHE F70NRTYRE or	1	PHF TB2012X...MM	1	PHE SM25...DBSE	1	PHF 2517X...MM	1
	PHE F70HTBFLG	1	PHE F70FRTYRE	–	PHF TB2012X...MM	1	–	–	–	–
H/H combination	PHE F70HTBFLG	1	PHE F70NRTYRE or	1	PHF TB1610X...MM	1	PHE SM25...DBSE	1	PHF 2517X...MM	1
	PHE F70HTBFLG	1	PHE F70FRTYRE	–	PHF TB1610X...MM	1	–	–	–	–
F/H combination	PHE F70FTBFLG	1	PHE F70NRTYRE or	1	PHF TB1610X...MM	1	PHE SM25...DBSE	1	PHF 2517X...MM	1
	PHE F70HTBFLG	1	PHE F70FRTYRE	–	PHF TB2012X...MM	1	–	–	–	–
Reversible	PHE F70RTBFLG	2	PHE F70NRTYRE	1	PHF TB1610X...MM	2	–	–	–	–

¹⁾ To complete designation, add distance between shaft ends. PHE SM25-100DBSE.

An SKF Flex coupling consists of 2 flanges and 1 tyre. An SKF Flex spacer coupling consists of 2 flanges, 1 tyre and 1 spacer (spacer part number consists of spacer shaft and rigid flange).

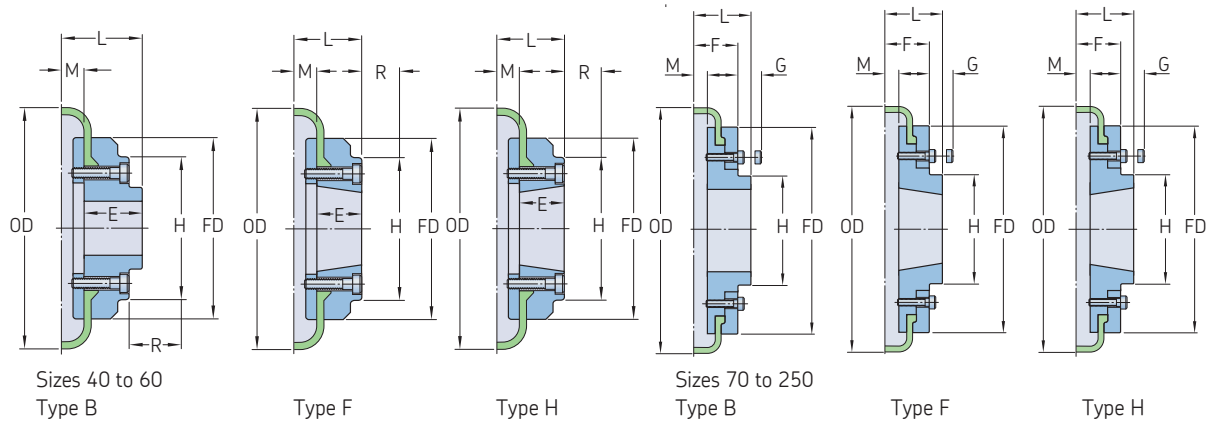

Size	Type	Bushing number	Bore	Dimensions											Mass	Inertia	Designation	Tyre designation			
				Types F & H		Type B		Key screw	OD	FD	H	F	R ¹⁾	G ²⁾				M	Natural	F.R.A.S	
mm	-	-	mm		L	E	L								E	OD	FD				H
40	B	-	11	30	-	-	33,0	22	M5	104	82,0	-	-	29	-	11,0	0,8	0,000074	PHE F40RSBFLG	PHE F40NRTYRE	PHE F40FRTYRE
40	F	1008	9	25	33,0	22	-	-	-	104	82,0	-	-	29	-	11,0	0,8	0,000074	PHE F40FTBFLG	PHE F40NRTYRE	PHE F40FRTYRE
40	H	1008	9	25	33,0	22	-	-	-	104	82,0	-	-	29	-	11,0	0,8	0,000074	PHE F40HTBFLG	PHE F40NRTYRE	PHE F40FRTYRE

¹⁾ The clearance required to allow tightening of the clamping screws and the taper bushing. Use of a shortened wrench will reduce this dimension.
²⁾ The amount by which the clamping screws need to be withdrawn to release the tyre.
 For coupling sizes 70, 80, 100 and 120, "F" flanges require a larger bushing than "H" flanges.
 Mass and inertia figures are for a single flange with midrange bore and include clamping ring, screws, washers and half tyre.

SKF Flex spacer coupling

The SKF Flex coupling spacer is used to join two shafts ends that cannot be positioned close enough to allow use of just a coupling.

The spacer also allows removal of a shaft without the need to move either the driving or the driven machine. For example, this allows easy and fast replacement of impellers in pump applications.

Coupling size	Distance between shaft ends (DBSE) Nominal		Spacer bushing number	Bore		Coupling bushing number	Bore		Designation
	Min.	Max.		Min.	Max.		Min.	Max.	
mm									
40	80	90	1210	11	32	1008	9	25	PHE SM12-80DBSE
40	100	110	1210	11	32	1008	9	25	PHE SM12-100DBSE
40	100	113	1615	14	42	1008	9	25	PHE SM16-100DBSE
40	140	150	1615	14	42	1008	9	25	PHE SM16-140DBSE
50	100	116	1615	14	42	1210	11	32	PHE SM16-100DBSE
50	140	156	1615	14	42	1210	11	32	PHE SM16-140DBSE
60	100	124	1615	14	42	1610	14	42	PHE SM16-100DBSE
60	140	164	1615	14	42	1610	14	42	PHE SM16-140DBSE
70	100	114	2517	16	60	2012	14	50	PHE SM25-100DBSE
70	140	154	2517	16	60	2012	14	50	PHE SM25-140DBSE
70	180	194	2517	16	60	2012	14	50	PHE SM25-180DBSE
80	100	117	2517	16	60	2517	16	60	PHE SM25-100DBSE
80	140	157	2517	16	60	2517	16	60	PHE SM25-140DBSE
80	180	197	2517	16	60	2517	16	60	PHE SM25-180DBSE
90	140	158	2517	16	60	2517	16	60	PHE SM25-140DBSE
90	180	198	2517	16	60	2517	16	60	PHE SM25-180DBSE
100	140	158	3020	25	75	3020	25	75	PHE SM30-140DBSE
100	180	198	3020	25	75	3020	25	75	PHE SM30-180DBSE
110	140	156	3020	25	75	3020	25	75	PHE SM30-140DBSE
110	180	196	3020	25	75	3020	25	75	PHE SM30-180DBSE
120	140	160	3525	35	100	3525	35	100	PHE SM35-140DBSE
120	180	200	3525	35	100	3525	35	100	PHE SM35-180DBSE
140	140	163	3525	35	100	3525	35	100	PHE SM35-140DBSE
140	180	203	3525	35	100	3525	35	100	PHE SM35-180DBSE

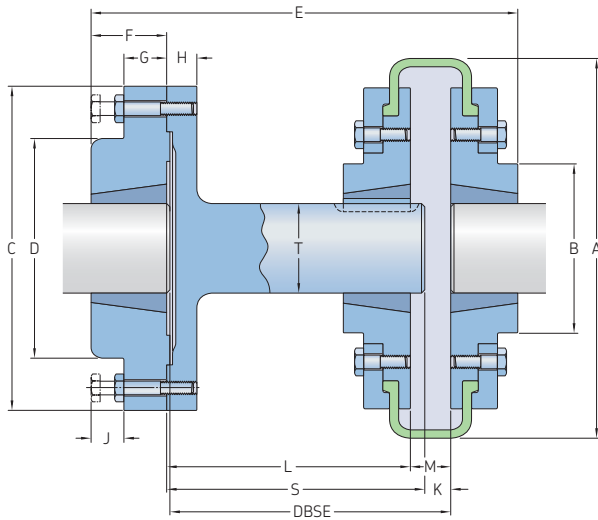

Coupling size	Dimensions														Designation
	A	B	C	D	E	F	G	H	J	K	L	M	S	T	
mm															-
40	104	82	118	83	134	25	14	15	14	6	65	22	77	25	PHE SM12-80DBSE
40	104	82	118	83	140	25	14	15	14	22	77	22	77	25	PHE SM12-100DBSE
40 ¹⁾	104	82	127	80	157	38	18	15	14	9	88	22	94	32	PHE SM16-100DBSE
40 ¹⁾	104	82	127	80	187	38	18	15	14	9	128	22	134	32	PHE SM16-140DBSE
50	133	79	127	80	160	38	18	15	14	9	85	25	94	32	PHE SM16-100DBSE
50	133	79	127	80	200	38	18	15	14	9	125	25	134	32	PHE SM16-140DBSE
60	165	103	127	80	161	38	18	15	14	9	78	33	94	32	PHE SM16-100DBSE
60	165	103	127	80	201	38	18	15	14	9	118	33	134	32	PHE SM16-140DBSE
70 ²⁾	187	80	178	123	180	45	22	16	14	9	80	23	94	48	PHE SM25-100DBSE
70 ²⁾	187	80	178	123	220	45	22	16	14	9	120	23	174	48	PHE SM25-140DBSE
70 ²⁾	187	80	178	123	260	45	22	16	14	9	160	23	174	48	PHE SM25-180DBSE
80	211	95	178	123	193	45	22	16	14	9	78	25	94	48	PHE SM25-100DBSE
80	211	95	178	123	233	45	22	16	14	9	118	25	134	48	PHE SM25-140DBSE
80	211	95	178	123	273	45	22	16	14	9	158	25	174	48	PHE SM25-180DBSE
90	235	108	178	123	233	45	22	16	14	9	116	27	134	48	PHE SM25-140DBSE
90	235	108	178	123	273	45	22	16	14	9	156	27	174	48	PHE SM25-180DBSE
100	254	120	216	146	245	51	29	20	17	9	116	27	134	60	PHE SM30-140DBSE
100	254	120	216	146	285	51	29	20	17	9	156	27	174	60	PHE SM30-180DBSE
110	279	134	216	146	245	51	29	20	17	9	118	25	134	60	PHE SM30-140DBSE
110	279	134	216	146	285	51	29	20	17	9	158	25	174	60	PHE SM30-180DBSE
120	314	140	248	178	272	63	34	20	17	9	114	29	134	80	PHE SM35-140DBSE
120	314	140	248	178	312	63	34	20	17	9	154	29	174	80	PHE SM35-180DBSE
140	359	178	248	178	271	63	34	20	17	9	111	27	134	80	PHE SM35-140DBSE
140	359	178	248	178	312	63	34	20	17	9	151	27	174	80	PHE SM35-180DBSE

¹⁾ F40 "B" Flange must be used to fit spacer shaft
²⁾ "F" Flange must be used to fit spacer shaft

Chain couplings

Chain couplings are able to transmit higher torque than their shafts, making them ideal for high torque applications. Available with a pilot bore, finished bore or tapered bushing (face or hub), flanges are linked together with duplex roller chains enabling them to accommodate up to 2 degrees of misalignment.

To provide maximum service life and reliability, particularly for high speed applications, SKF recommends fitting all chain couplings with a cover and lubricating them properly. If a chain coupling is to be subjected to reversing operations, shock or pulsating loads, or other severe operating conditions, select a coupling one size larger than normal.

Coupling covers

Cover size	Aluminium		Weight	Plastic		Weight
	D	W		D	W	
–	mm		kg	mm		kg
IS0816 ¹⁾	101,6	50,8	0,42	101,6	58,7	0,90
IS1016 ¹⁾	130,2	60,3	0,59	130,2	66,7	1,32
IS1018 ¹⁾	130,2	60,3	0,59	130,2	66,7	1,32
IS1218 ¹⁾	161,9	74,6	1,20	175,0	77,8	1,98
IS1220 ¹⁾	161,9	74,6	1,20	175,0	77,8	1,98
IS1222 ¹⁾	208,0	101,6	1,45	175,0	77,8	2,22
IS1618 ¹⁾	208,0	101,6	1,45	210,0	106,0	2,22
IS1620 ¹⁾	208,0	101,6	1,45	210,0	106,0	2,22
IS2018	257,2	133,4	4,80	238,1	150,8	3,97
IS2020	257,2	133,4	4,80	257,2	133,4	5,74
IS2418	288,9	187,3	8,10	288,9	187,3	7,47
IS2422	336,6	201,6	9,20	336,6	201,6	8,85

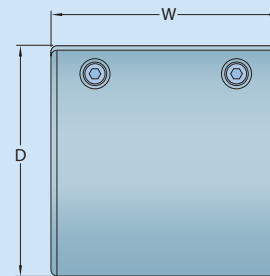

¹⁾ Will be supplied in plastic unless otherwise specified

Order data

Size	Hub			Chain						Covers					
	Plain Bore	Qty	FTB ¹⁾	Qty	HTB ¹⁾	Qty	Bored to size ²⁾	Qty	Qty	Qty	Qty				
816	PHE IS0816RSB	2	and/or	PHE IS0816FTB	2	and/or	PHE IS0816HTB	2	and/or	PHE IS0816X...	2	PHE IS0816CHN	1	PHE IS0816COVER	1
1016	PHE IS1016RSB	2	and/or	–	2	and/or	–	2	and/or	PHE IS1016X...	2	PHE IS1016CHN	1	PHE IS1016COVER	1
1018	PHE IS1018RSB	2	and/or	PHE IS1018FTB	2	and/or	PHE IS1018HTB	2	and/or	PHE IS1018X...	2	PHE IS1018CHN	1	PHE IS1018COVER	1
1218	PHE IS1218RSB	2	and/or	–	2	and/or	–	2	and/or	PHE IS1218X...	2	PHE IS1218CHN	1	PHE IS1218COVER	1
1220	PHE IS1220RSB	2	and/or	PHE IS1220FTB	2	and/or	PHE IS1220HTB	2	and/or	PHE IS1220X...	2	PHE IS1220CHN	1	PHE IS1220COVER	1
1222	PHE IS1222RSB	2	and/or	–	2	and/or	–	2	and/or	PHE IS1222X...	2	PHE IS1222CHN	1	PHE IS1222COVER	1
1618	PHE IS1618RSB	2	and/or	–	2	and/or	–	2	and/or	PHE IS1618X...	2	PHE IS1618CHN	1	PHE IS1618COVER	1
1620	PHE IS1620RSB	2	and/or	PHE IS1620FTB	2	and/or	PHE IS1620HTB	2	and/or	PHE IS1620X...	2	PHE IS1620CHN	1	PHE IS1620COVER	1
2018	PHE IS2018RSB	2	and/or	–	2	and/or	–	2	and/or	PHE IS2018X...	2	PHE IS2018CHN	1	PHE IS2018COVER	1
2020	PHE IS2020RSB	2	and/or	PHE IS2020FTB	2	and/or	PHE IS2020HTB	2	and/or	PHE IS2020X...	2	PHE IS2020CHN	1	PHE IS2020COVER	1
2418	PHE IS2418RSB	2	and/or	–	2	and/or	–	2	and/or	PHE IS2418X...	2	PHE IS2418CHN	1	PHE IS2418COVER	1
2422	PHE IS2422RSB	2	and/or	–	2	and/or	–	2	and/or	PHE IS2422X...	2	PHE IS2422CHN	1	PHE IS2422COVER	1

A complete chain coupling consists of: 2 hubs, 1 chain and 1 cover.

¹⁾ Following chain coupling taper bush assembly configurations are possible: 2 hubs HTB or 2 hubs FTB or 1 hub HTB and 1 hub FTB.

²⁾ To complete bored to size designation, add bore size. For example: PHE IS1016X22MM designates hub size IS1016 with a 22 mm bore.

Chain couplings

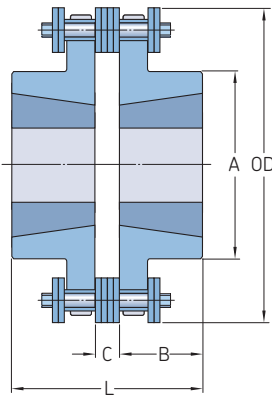

Assembly configuration HH

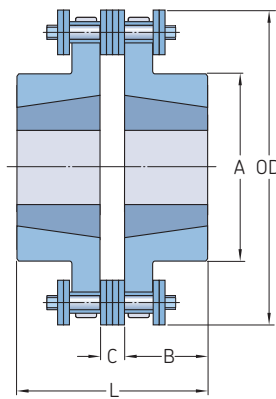

Assembly configuration FF

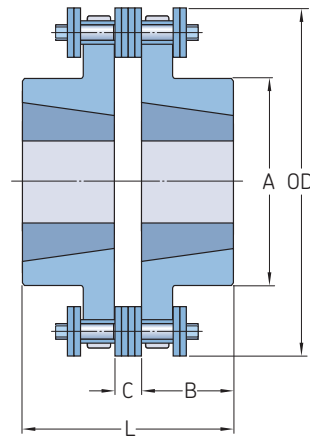

Assembly configuration FH

Coupling size	Bushing number	Bore		Dimensions					Mass	Speed	Nominal torque	Chain mass	Hub designation			Bored to size	
		Min.	Max.	A	B	C	L	OD					Plain bore	FTB	HTB		
-	-	mm							kg	r/min	Nm	kg	-				
0816	- 1108	15,9 12,7	23,8 28,6	50,0 50,0	28,96 22,20	7,1 7,1	65,0 51,6	77,0 77,0	0,45 0,41	5 000 5 000	294 294	0,23 0,23	PHE IS0816RSB -	- PHE IS0816FTB	- PHE IS0816HTB	-	PHE IS0816X...
1016	-	15,9	42,9	63,5	36,88	9,5	83,3	96,0	1,00	4 000	559	0,54	PHE IS1016RSB	-	-	-	PHE IS1016X...
1018	- 1610	19,1 12,7	50,8 41,3	75,4 75,4	43,26 25,40	9,5 9,5	87,1 60,3	106,4 106,4	1,59 0,50	3 600 3 600	706 706	0,59 0,59	PHE IS1018RSB -	- PHE IS1018FTB	- PHE IS1018HTB	-	PHE IS1018X...
1218	-	25,4	61,9	88,9	47,60	11,1	106,3	127,0	2,27	3 000	1 333	1,00	PHE IS1218RSB	-	-	-	PHE IS1218X...
1220	- 2012	28,6 12,7	69,9 50,8	98,4 98,4	50,80 31,80	11,1 11,1	112,7 74,6	139,7 139,7	2,95 1,23	2 500 2 500	1 559 1 559	1,18 1,18	PHE IS1220 -	- PHE IS1220FTB	- PHE IS1220HTB	-	PHE IS1220X...
1222	-	28,6	76,2	114,3	54,00	11,1	119,1	151,2	4,31	2 500	1 794	1,23	PHE IS1222RSB	-	-	-	PHE IS1222X...
1618	-	28,6	79,4	115,9	60,70	14,7	136,1	169,1	4,99	2 000	2 961	2,40	PHE IS1618RSB	-	-	-	PHE IS1618X...
1620	- 3020	38,1 23,8	90,5 76,2	136,5 136,5	66,10 50,00	14,7 14,7	146,9 116,3	185,3 185,3	7,40 2,77	2 000 2 000	3 579 3 579	2,68 2,68	PHE IS1620RSB -	- PHE IS1620FTB	- PHE IS1620HTB	-	PHE IS1620X...
2018	-	38,1	98,4	144,5	70,90	18,3	160,1	211,5	9,21	1 800	4 981	4,45	PHE IS2018RSB	-	-	-	PHE IS2018X...
2020	- 3535	38,1 30,2	117,5 88,9	170,7 170,7	79,80 88,90	18,3 18,3	177,9 196,1	231,8 231,8	14,43 8,62	1 800 1 800	6 688 6 688	4,95 4,95	PHE IS2020RSB -	- PHE IS2020FTB	- PHE IS2020HTB	-	PHE IS2020X...
2418	-	50,8	119,1	171,5	88,30	21,8	198,4	254,0	16,70	1 500	10 032	7,85	PHE IS2418RSB	-	-	-	PHE IS2418X...
2422	-	50,8	155,6	222,3	102,10	21,8	226,0	302,0	31,76	1 200	12 993	9,62	PHE IS2422RSB	-	-	-	PHE IS2422X...

Rigid couplings

Taper bush rigid couplings provide a convenient method of rigidly connecting ends of shafts. Taper bushes permit easier and quicker fixing to the shafts with the firmness of a shrunk on fit. These couplings have a fully machined male and female flange. The male flange can have the bushing fitted from the hub side A (MH) or from the flange side B (H); the female flange (F) always has the bushing fitted from the flange side B. This gives two possible coupling assemblies: AB and BB. When connecting horizontal shafts, the most convenient assembly should be chosen. For connecting vertical shafts, use assembly BB only.

Order data

Coupling assembly	Male	Qty	Female	Qty	
A/B	PHE R12MHTB	1	PHE R12FTB	1	
	PHE R16MHTB	1	PHE R16FTB	1	
	PHE R25MHTB	1	PHE R25FTB	1	
	PHE R30MHTB	1	PHE R30FTB	1	
	PHE R35MHTB	1	PHE R35FTB	1	
	PHE R40MHTB	1	PHE R40FTB	1	
	PHE R45MHTB	1	PHE R45FTB	1	
	PHE R50MHTB	1	PHE R45FTB	1	
	B/B	PHE R12HTB	1	PHE R12FTB	1
		PHE R16HTB	1	PHE R16FTB	1
		PHE R25HTB	1	PHE R25FTB	1
		PHE R30HTB	1	PHE R30FTB	1
PHE R35HTB		1	PHE R35FTB	1	
PHE R40HTB		1	PHE R40FTB	1	
PHE R45HTB		1	PHE R45FTB	1	
PHE R50HTB		1	PHE R50FTB	1	

A complete coupling consists of one male and one female flange.
 Example: Coupling assembly AB PHE R12MHTB and PHE R12FTB
 Coupling assembly BB PHE R12HTB and PHE R12FTB

Rigid couplings

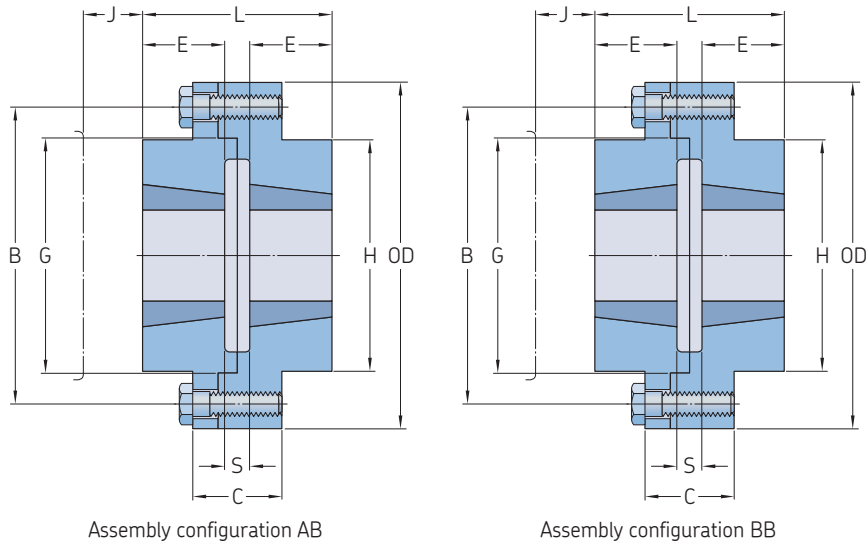

Coupling size	Bushing data Bushing number	Bore Max.	Dimensions									Mass ³⁾ kg	
			D	C	E	H	G Nominal	B Nominal	S ¹⁾	J ²⁾	L		
–	–	mm	mm										
R12	1210	32	118	35	25	83	76	102	7	38	57	3,5	
R16	1615	42	127	43	38	80	89	105	7	38	83	4,5	
R25	2517	60	178	51	45	123	127	149	7	48	97	11,0	
R30	3020	75	216	65	51	146	152	181	7	54	109	20,0	
R35	3525	100	248	75	65	178	178	213	7	67	137	34,0	
R40	4030	110	298	76	76	210	216	257	7	79	159	59,0	
R45	4535	125	330	86	89	230	241	246	7	89	185	80,0	
R50	5040	125	362	92	102	266	267	314	7	92	211	135,0	

¹⁾ J is the wrench clearance to allow for tightening and loosening the bushing on the shaft. The use of a shortened wrench will permit this dimension to be reduced

²⁾ S is the distance between shaft ends

³⁾ Mass given is for couplings with midrange taper bushings.

FRC couplings

With a higher load capacity than jaw couplings and maintenance-free operation, FRC couplings are designed as a general purpose coupling. They are able to cushion moderate shock loads, dampen low levels of vibration and accommodate incidental misalignment. FRC couplings offer a range of hub and element selection to meet the demand for low cost, general purpose flexible coupling.

FRC couplings are phosphate coated for improved corrosion resistance and available with fire-resistant and anti-static elements (FRAS). FRC couplings are available with a pilot bore, finished bore or tapered bushing (face or hub) to make installation quick and simple.

Fully machined outside surfaces allow alignment with a simple straight edge. Shaft connections are fail safe due to their interlocking jaw design.

Assembled coupling characteristics

Size	Assembled length comprising flange types			Mass	Inertia	Torsional stiffness	Misalignment			Nominal torque	Max torque
	FF,FH,HH	FB,HB	BB				Angular	Parallel	Axial		
–	mm			kg	kg/m ²	Nm/°	°	mm		Nm	
70	65,0	65,0	65,0	1,00	0,00085	–	1	0,3	0,2	31,5	72
90	69,5	76,0	82,5	1,17	0,00115	–	1	0,3	0,5	80,0	180
110	82,0	100,5	119,0	5,00	0,004	65	1	0,3	0,6	160,0	360
130	89,0	110,0	131,0	5,46	0,0078	130	1	0,4	0,8	315,0	720
150	107,0	129,5	152,0	7,11	0,0181	175	1	0,4	0,9	600,0	1 500
180	142,0	165,5	189,0	16,60	0,0434	229	1	0,4	1,1	950,0	2 350
230	164,5	202,0	239,5	26,00	0,1207	587	1	0,5	1,3	2 000,0	5 000
280	207,5	246,5	285,5	50,00	0,4465	1 025	1	0,5	1,7	3 150,0	7 200

Mass is for an FF, FH or HH coupling with mid range taper bushes.

Order data

Coupling type	Flanges	Qty	Element	Qty	Taper bush	Qty
RSB both sides	PHE FRC70RSB	2	PHE FRC70NR or PHE FRC70FR	1	–	–
RSB/F Combination	PHE FRC70RSB PHE FRC70FTB	1 1	PHE FRC70NR or PHE FRC70FR	1 –	PHF TB1008X...MM	1 1
RSB/H Combination	PHE FRC70RSB PHE FRC70HTB	1 1	PHE FRC70NR or PHE FRC70FR	1 –	PHF TB1008X...MM	1 1
F/F Combination	PHE FRC70FTB PHE FRC70FTB	1 1	PHE FRC70NR or PHE FRC70FR	1 –	PHF TB1008X...MM PHF TB1008X...MM	1 1
H/H Combination	PHE FRC70HTB PHE FRC70HTB	1 1	PHE FRC70NR or PHE FRC70FR	1 –	PHF TB1008X...MM PHF TB1008X...MM	1 1
F/H Combination	PHE FRC70FTB PHE FRC70HTB	1 1	PHE FRC70NR or PHE FRC70FR	1 –	PHF TB1008X...MM PHF TB1008X...MM	1 1

NR = Natural rubber

FR = Fire-resistant and anti-static (FRAS)

A complete FRC coupling consists of: 2 hubs and 1 element.

FRC couplings

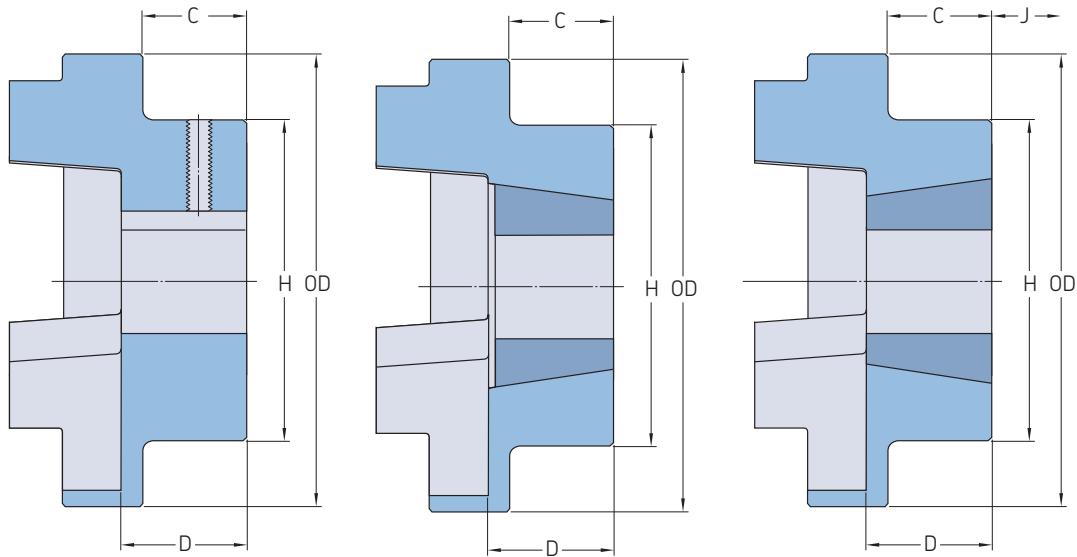

Coupling size	Dimensions		Bushing number Type F, H	Bore		C	D	J ¹⁾	Type B	Bore	Key screw	C	D
	OD	H		Min.	Max.				Max.				
— mm													
70	69	60	1008	9	25	20,0	23,5	29	32	10	M6	20	25,8
90	85	70	1108	9	28	19,5	23,5	29	38	10	M6	26	30,0
110	112	100	1610	14	42	18,5	26,5	38	55	10	M10	37	45,3
130	130	105	1610	14	42	18,0	26,5	38	60	20	M10	39	47,5
150	150	115	2012	14	50	23,5	33,5	42	70	28	M10	46	60,0
180	180	125	2517	16	60	34,5	46,5	48	80	28	M10	58	70,0
230	225	155	3020	25	75	39,5	52,5	55	100	45	M12	77	90,0
280	275	206	3525	35	100	51,0	66,5	67	115	55	M16	90	105,5

¹⁾ Clearance required for tightening/loosening the bushing on the shaft

Jaw couplings

Jaw couplings provide a cost-effective solution for standard power applications, helping to cushion moderate shock loads and dampen low vibration levels.

Maintenance-free and easy to install, jaw couplings are available with a snap wrap element allowing element replacement in situ.

Urethane and Hytrel® elements have a greater power rating than nitrile elements and are recommended for applications where a compact, high torque solution is required.

Standard bore and keyway chart

Bore	Keyway	Coupling Size									
		50	70	75	90	95	100	110	150	190	225
mm											
9	3 x 1,4	X	X	X	X	-	-	-	-	-	-
10	3 x 1,4	X	X	X	X	-	-	-	-	-	-
11	4 x 1,8	X	X	X	X	-	-	-	-	-	-
12	4 x 1,8	X	X	X	X	X	-	-	-	-	-
14	5 x 2,3	X	X	X	X	X	X	-	-	-	-
15	5 x 2,3	-	X	X	X	X	X	-	-	-	-
16	5 x 2,3	-	X	X	X	X	X	X	-	-	-
17	5 x 2,3	-	X	X	X	X	X	X	X	-	-
18	6 x 2,8	-	X	X	X	X	X	X	X	-	-
19	6 x 2,8	-	X	X	X	X	X	X	X	X	-
20	6 x 2,8	-	-	X	X	X	X	X	X	X	-
22	6 x 2,8	-	-	X	X	X	X	X	X	X	-
24	8 x 3,3	-	-	-	X	X	X	X	X	X	X
25	8 x 3,3	-	-	-	-	X	X	X	X	X	X
28	8 x 3,3	-	-	-	-	X	X	X	X	X	X
30	8 x 3,3	-	-	-	-	-	X	X	X	X	X
32	10 x 3,3	-	-	-	-	-	X	X	X	X	X
35	10 x 3,3	-	-	-	-	-	X	X	X	X	X
38	10 x 3,3	-	-	-	-	-	X	X	X	X	X
40	12 x 3,3	-	-	-	-	-	-	X	X	X	X
42	12 x 3,3	-	-	-	-	-	-	X	X	X	X
45	14 x 3,8	-	-	-	-	-	-	-	X	X	X
48	14 x 3,8	-	-	-	-	-	-	-	X	X	X
50	14 x 3,8	-	-	-	-	-	-	-	-	X	X
55	16 x 4,3	-	-	-	-	-	-	-	-	X	X
60	18 x 4,4	-	-	-	-	-	-	-	-	-	X

Order data

Coupling type	Flanges	Qty	Element	Qty	Spacer shaft	Qty	Nitrile wrap element	Qty	Ring kit	Qty
RSB both sides	PHE L095HUB	2	PHE L095NR or	1	PHE L090X ... SPACER	1	PHE L090NRWRAP	2	PHE L090RINGKIT	2
	-	-	PHE L095UR	-	-	-	-	-	-	-
	-	-	PHE L095HL	-	-	-	-	-	-	-
Bore with keyway/RSB combination	PHE L095HUB	1	PHE L095NR or	1	PHE L090X ... SPACER	1	PHE L090NRWRAP	2	PHE L090RINGKIT	2
	PHE L095 - ... MM	1	PHE L095UR	-	-	-	-	-	-	-
	-	-	PHE L095HL	-	-	-	-	-	-	-
Bore with keyway on both sides	PHE L095 - ... MM	2	PHE L095NR or	1	PHE L090X ... SPACER	1	PHE L090NRWRAP	2	PHE L090RINGKIT	2
	-	-	PHE L095UR	-	-	-	-	-	-	-
	-	-	PHE L095HL	-	-	-	-	-	-	-
Bore only/RSB combination	PHE L095 - ... MMP	1	PHE L095NR or	1	PHE L090X ... SPACER	1	PHE L090NRWRAP	2	PHE L090RINGKIT	2
	PHE L095HUB	1	PHE L095UR	-	-	-	-	-	-	-
	-	-	PHE L095HL	-	-	-	-	-	-	-
Bore only	PHE L095 - ... MMP	2	PHE L095NR or	1	PHE L090X ... SPACER	1	PHE L090NRWRAP	2	PHE L090RINGKIT	2
	-	-	PHE L095UR	-	-	-	-	-	-	-
	-	-	PHE L095HL	-	-	-	-	-	-	-
Bore only/bore with keyway combination	PHE L095 - ... MMP	1	PHE L095NR or	1	PHE L090X ... SPACER	1	PHE L090NRWRAP	2	PHE L090RINGKIT	2
	PHE L095 - ... MM	1	PHE L095UR	-	-	-	-	-	-	-
	-	-	PHE L095HL	-	-	-	-	-	-	-

NR = Nitrile
UR = Urethane
HL = Hytrel®

A complete jaw coupling consists of: 2 hubs and 1 element and a complete coupling with spacer consists of 2 hubs, 2 nitrile elements, 2 ring kits and 1 spacer.

Available spacer shaft lengths are 100 mm and 140 mm. To complete the designation, add spacer length. For example: PHE L090X100SPACER for spacer of 100 mm, coupling size 090.

When ordering bored to size and keywayed hubs, it is required that the bore diameter is added to the designation found in the table above.

Where a keyway is NOT required, the designation should be suffixed with a P.

PHE L150-18MM = Hub Size 150 with 18 mm bore and keyway.

PHE L070-16MMP = Hub Size 070 with 16 mm bore (no keyway).

Jaw couplings

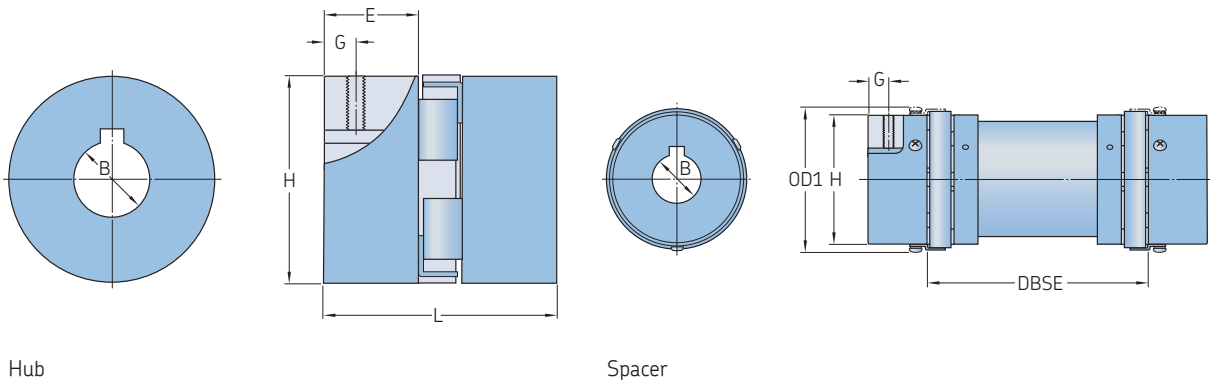

Size	Dimensions								Set screw	Approx mass ²⁾	Speed	Designation
	Bore	Pilot	Max.	OD	OD1 ¹⁾	L	E	H				
–	mm	–	–	–	–	–	–	–	–	kg	r/min	–
35	3,20	9,5	15,9	–	20,6	6,7	15,9	–	–	0,03	31 000	PHE L035HUB
50	6,35	14,0	27,5	–	44,0	16,0	27,5	6,5	M6	0,05	18 000	PHE L050HUB
70	6,35	19,0	35,0	–	51,0	19,0	35,0	9,5	M6	0,13	14 000	PHE L070HUB
75	6,35	24,0	44,5	–	54,0	21,0	44,5	9,0	M6	0,22	11 000	PHE L075HUB
90	6,35	24,0	54,0	–	54,0	21,0	54,0	8,7	M6	0,28	9 000	PHE L090HUB
95	11,11	28,0	54,0	64	64,0	25,0	54,0	11,0	M8	0,28	9 000	PHE L095HUB
100	12,70	35,0	65,0	77	89,0	35,0	65,0	11,0	M8	0,75	7 000	PHE L100HUB
110	15,87	42,0	84,0	97	108,0	43,0	84,0	19,0	M10	1,50	5 000	PHE L110HUB
150	15,87	48,0	96,0	112	115,0	45,0	96,0	22,0	M10	2,40	4 000	PHE L150HUB
190	19,05	55,0	115,0	130	133,0	54,0	102,0	22,0	M12	3,50	3 600	PHE L190HUB
225	19,05	60,0	127,0	143	153,0	64,0	108,0	29,0	M12	4,50	3 600	PHE L225HUB

¹⁾ Outer diameter of ring kit

²⁾ Mass of hub with pilot bores

DBSE = Distance between shaft ends

Hub material is high grade cast iron. Spacer material is aluminium.

Universal joints

SKF universal joints, also known as pin and block couplings, are commonly used for low to medium torque industrial, off-road and agricultural applications.

These couplings offer an economical solution for applications up to 1 800 r/min and will provide working angles of up to 25% or 35% for manual drives. SKF offers these couplings with a solid bore from stock; bored to size, square, hexagonal and round bores on request. The couplings are available in either a single (UJMA) or double (UJMB) configuration.

Order data

Universal joint type	Size	Qty
Single	PHE UJMA10	1
Double	PHE UJMB20	1

Available on request with finish bore, finish bore with keyway, hexagonal bore or square bore, e.g. the designations as shown below:

Universal joints with finish bore H7, with keyway (BSX30MM) – PHE UJMB45BSX30MM
Universal joints with finish bore H7, without keyway (X30MM) – PHE UJMB45X30MM
Universal joints with hexagonal bore (HBX30MM) – PHE UJMB45HBX30MM
Universal joints with square bore (SBX30MM) – PHE UJMB45SBX30MM

Universal joints

Single universal joints | Double universal joints

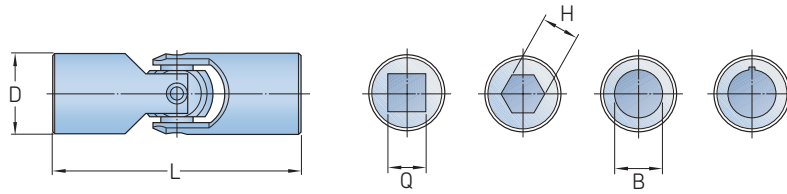

Size	Dimensions		Bore		Q	H	B Max.	B with keyway Max.	Static breaking torque	Designation
	L	D	B							
–	mm								Nm	–
10	38	10	6	6	6	6	6	–	13,5	PHE UJMA10
13	45	13	8	8	8	8	8	–	26,0	PHE UJMA13
16	52	16	8	8	8	8	10	8	45,0	PHE UJMA16
20	62	20	10	10	10	10	13	11	88,0	PHE UJMA20
25	74	25	12	12	12	12	16	14	180,0	PHE UJMA25
32	86	32	16	16	16	16	22	18	405,0	PHE UJMA32
40	108	40	20	20	20	20	25	22	860,0	PHE UJMA40
45	120	45	20	20	20	20	30	25	1 250,0	PHE UJMA45
50	132	50	25	25	25	25	35	30	1 730,0	PHE UJMA50
63	166	63	32	–	–	–	45	35	3 400,0	PHE UJMA63
75	190	75	40	–	–	–	55	45	5 300,0	PHE UJMA75

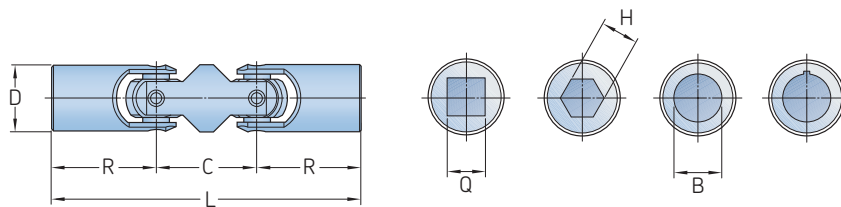

Size	Dimensions				Bore		B with keyway Max.	Q	H	Static breaking torque	Designation
	L	R	D	C	B	B Max.					
–	mm								Nm	–	
13	68	22,5	13	23	8	8	–	8	8	26	PHE UJMB13
16	77	26,0	16	25	8	10	8	8	8	45	PHE UJMB16
20	92	31,0	20	30	10	13	11	10	10	88	PHE UJMB20
25	110	37,0	25	36	12	16	14	12	12	180	PHE UJMB25
32	133	43,0	32	47	16	22	18	16	16	405	PHE UJMB32
40	164	54,0	40	56	20	25	22	20	20	860	PHE UJMB40
45	183	60,0	45	63	20	30	25	20	20	1 250	PHE UJMB45
50	202	66,0	50	70	25	35	30	25	25	1 730	PHE UJMB50
63	250	83,0	63	84	32	45	35	32	–	3 400	PHE UJMB63
75	290	95,0	75	100	40	55	45	40	–	5 300	PHE UJMB75



更詳細的可靠度系統產品資訊請連絡

億寶軸承股份有限公司

電話:(03)378-2168

傳真:(03)369-7306

地址:330059 桃園市桃園區文中路425號

信箱:eb.bearing@msa.hinet.net



www.eb-bearing.com.tw

eb BEARING